

Leica RoadRunner Technical Reference Manual



Version 5.5
English

- when it has to be **right**

Leica
Geosystems

Introduction

Purchase

Congratulations on the purchase of a RoadRunner application.



To use the product in a permitted manner, please refer to the detailed safety directions in the User Manual.

Product identification

The type and the serial number of your product are indicated on the type plate. Enter the type and serial number in your manual and always refer to this information when you need to contact your agency or Leica Geosystems authorized service workshop.

Type: _____

Serial No.: _____

Symbols

The symbols used in this manual have the following meanings:

Type	Description
	Important paragraphs which must be adhered to in practice as they enable the product to be used in a technically correct and efficient manner.

Trademarks

- Windows and Windows CE are a registered trademark of Microsoft Corporation
 - CompactFlash and CF are trademarks of SanDisk Corporation
 - Bluetooth is a registered trademark of Bluetooth SIG, Inc
- All other trademarks are the property of their respective owners.

Validity of this manual

This manual can apply to GPS900, GPS1200, all RX1250 controllers and TPS1200.

The following main softkeys refer to GPS900, GPS1200 and RX1250 in GPS mode.

They have the same functions in all manuals referring to GPS900, GPS1200, RX1250.

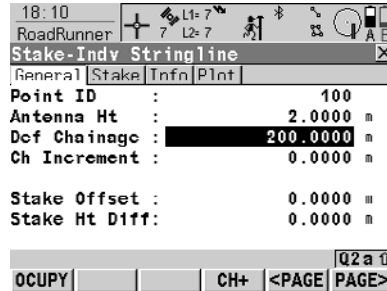

Softkey	Description of Softkey
OCUPY (F1)	To start measuring the point being staked. The position mode icon changes to the static icon. (F1) changes to STOP . The difference between the current position and the point being staked is still displayed.
STOP (F1)	To end measuring the point being staked. When Auto STOP: Yes in CONFIGURE Point Occupation Settings , recording of positions ends automatically as defined by the stop criteria. The position mode icon changes to the moving icon. (F1) changes to STORE . After ending the measurements, the differences between the measured point and the point to be staked are displayed.
STORE (F1)	To store the measured point. When Auto STORE: Yes in CONFIGURE Point Occupation Settings , the measured point is stored automatically. (F1) changes to OCUPY .

Softkey	Description of Softkey
SHIFT CONEC (F3) and SHIFT DISCO (F3)	To dial the number of the reference station configured in the active configuration set and to hang up immediately after the survey is completed. Available for OCUPY (F1) or STORE (F1) being displayed and for real-time devices of type digital cellular phone or modem. Available for Auto CONEC: No in CONFIGURE GSM Connection .
SHIFT INIT (F4)	To select an initialisation method and to force a new initialisation. Available for OCUPY (F1) or STORE (F1) being displayed and for configuration sets allowing phase fixed solutions. Refer to the "Technical Reference Manual".

The following main softkeys refer to TPS1200 and RX1250 in TPS mode

They have the same functions in all manuals referring to TPS1200, RX1250.

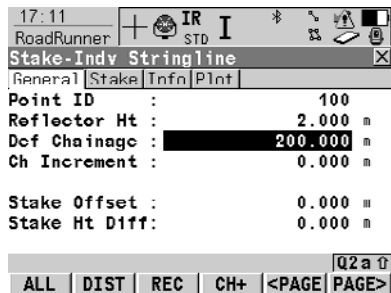

Softkey	Description of Softkey
ALL (F1)	To measure/record distances and angles.
DIST (F2)	To measure and display distances.
REC (F3)	To record/store the measured data.
SHIFT POSIT (F4)	To position the instrument, depending on the Auto Position setting.

Table of Contents

In this manual	Chapter	Page
	1 Step 1 - RoadRunner Begin	12
	2 Step 2 - RoadRunner Setup	16
	3 Step 3 - Working in Standard mode	22
	3.1 An Overview of the Define Page	22
	3.2 Selecting Layers and Stringlines	23
	3.3 The Define Page for Stringlines	25
	3.4 The Define Page for Individual Stringlines	26
	3.5 The Define Page for Cross Slopes	27
	3.6 The Define Page for Manual Slopes	28
	3.7 The Define Page for Design Slopes	30
	3.8 The Define Page for Crowns	31
	3.9 The Define Page for Layers	33
	3.10 The Define Page for Digital Terrain Models (DTM)	34
	4 Step 3 - Working in Advanced mode	36
	4.1 An Overview of Tasks	36
	4.2 Selecting Layers and Stringlines	38
	4.3 Creating/Editing Tasks with the Selection Wizard	39
	4.3.1 Overview	39
	4.3.2 Selection Wizard - Start Screen	41
	4.3.3 Selection Wizard - View Screen	44
	4.3.4 Selection Wizard - Select Screen	46

	4.3.5	Selection Wizard - Define Screen	49
	4.3.6	Selection Wizard - Slope Screen	57
	4.3.7	Selection Wizard - Shift Screen	61
	4.4	Selecting Stringlines, Indiv Stringlines or Centrelines	64
	4.5	Selecting X-Slopes	66
	4.6	Selecting Slopes	68
	4.7	Selecting Manual Slopes	72
	4.8	Selecting Layers	74
	4.9	Selecting Digital Terrain Models (DTM)	76
	4.10	Selecting Road Crowns	77
	4.11	The Zig Zag Mode	79
	4.12	Chainage Range	81
5		Step 4 - Measuring	82
	5.1	Staking/Checking the Road - An Overview of the Pages	82
	5.2	The General Page	84
	5.3	The Stake Page	87
	5.4	The Info Page	90
	5.5	The Plot Page	91
	5.6	Measuring Points by Chainage and Offset	95
	5.7	Measuring Stringlines Relative to a Centre Line	97
	5.8	Measuring Individual Stringlines without Centre Lines	99
	5.9	Measuring Cross Slopes	102
	5.10	Measuring Manual Slopes and Design Slopes	104
	5.10.1	Overview	104
	5.10.2	Defining the Slope Type - Using no Slope	106
	5.10.3	Defining the Slope Type - Using a Reference Point	107
	5.10.4	Defining the Slope Type - Using a Batter Rail	111
	5.10.5	Defining the Slope Type - Using a Reference Batter	115

5.11	Measuring Road Crowns	119
5.12	Measuring Road Layers	121
5.13	Measuring Digital Terrain Models (DTM)	122
6	Configuring	124
6.1	Overview of all Configuration Settings	124
6.2	Configuration Settings for the Project - Project Config	126
6.2.1	The General Page	126
6.2.2	The Posit Page (for TPS only)	130
6.3	Configuration Settings for the Program - Road Config	133
6.3.1	The General Page	133
6.3.2	The Check Page	138
6.3.3	The Info&Plot Page	142
6.3.4	The Logfile Page	144
6.4	Road Stake Out Info Page and Road Check Info Page	146
6.4.1	Overview	146
6.4.2	Changing Display Items of the Info Page	148
6.4.3	Info Page for Stringline	150
6.4.4	Info Page for Individual Stringline	155
6.4.5	Info Page for X-Slope	161
6.4.6	Info Page for Slope Manual and Slope	166
6.4.7	Info Page for Crown	172
6.4.8	Info Page for Layer	178
6.4.9	Info Page for DTM	183
6.5	Auto Positioning (TPS only)	186
6.5.1	Overview	186
6.5.2	Auto Position 2D + Measure	188
6.5.3	Auto Position Advanced	190

7	Managing the Project	192
7.1	Overview	192
7.2	Selecting a Project from Task Management	195
7.3	Selecting a Project by Resuming the Last Task (Advanced Mode)	196
7.4	Creating a New Project	197
7.5	Editing an Existing Project	198
7.6	Deleting an Existing Project	200
8	Managing the Road Job	202
8.1	Overview	202
8.2	Working with the Design Data (Stringlines and Layers)	203
8.3	Working with the Tasks (Advanced Mode)	206
8.4	Creating a New Road Job	207
8.5	Deleting an Existing Road Job	209
8.6	Working with a DTM Job	210
9	Viewing and Editing the Design Data	212
9.1	Overview	212
9.2	Viewing the Design Data	214
9.3	Editing the Design Data	220
10	Working with the Extras Menu	224
10.1	Overview	224
10.2	Common Extras - Manual/DTM Height	225
10.3	Common Extras - 2nd Height from DTM	227
10.4	Common Extras - Shift Reference Line	229
10.5	Common Extras - Reinitialise Search	233
10.6	Extras for Stringline	234
10.7	Extras for X-Slope, Layer and Crown	244

10.8	Extras for Slope	246
11	Understanding Stake and Check Basics	252
<hr/>		
11.1	Overview	252
11.2	Basic Terms	253
11.3	Basic Elements for Road Stake and Check Measurements	255
11.4	Shifts	259
	11.4.1 Overview	259
	11.4.2 Shifts for Stringlines, Slopes, Layers and DTM's	262
	11.4.3 Shift for X-Slopes and Road Crowns	263
11.5	Stake Offset and Stake Height Difference	265
11.6	Stake and Info Screens	267
	11.6.1 Overview	267
	11.6.2 Stake Offset / Height Difference Working Example	269
11.7	Methods for Slope Staking	273
	11.7.1 Overview	273
	11.7.2 General Slope Stake Out	275
	11.7.3 Slope Staking Using a Reference Point	276
	11.7.4 Slope Staking With Batter Rails	278
	11.7.5 Staking Batter Rails Using a Reference Point	279
11.8	Chainage or Station Equations	281
11.9	Working Corridor	284
12	Understanding the Geometry	286
<hr/>		
12.1	Horizontal and Vertical Geometry Elements	286
12.2	Horizontal and Vertical Shifts	287
12.3	Extension of Stringlines	290

13	Quick Start Tutorial (Advanced Mode)	292
13.1	Overview	292
13.2	Exercise 1a: Setting Up and Getting Started	295
13.3	Exercise 1b: Creating the Project and Task and also Configuring	301
13.4	Exercise 2: Staking the Centre Line	310
13.5	Exercise 3: Staking Out Slopes	316
13.6	Exercise 4: Checking Road Layer Surface	323
13.7	Exercise 5: Shifting Design to Fit Existing Road Level	330
	Index	336

1

Step 1 - RoadRunner Begin

Accessing the screens

Start the RoadRunner application or press ESC on the RoadRunner Setup screen.

Positioning the GPS

This screen shows the following:

To select the coordinate system, codelist, configuration set and antenna for the survey.

```

RoadRunner Begin [X]
Coord System :      WGS 1984
Codelist       :      <None> [↓]

Config Set    :      configure set [↓]
Antenna       :      ATX1230 SmartStn [↓]
  
```

```

[CONT] [CONF] [RESUM] [CSYS]
  
```

CONT (F1)

To continue to the next screen.

CONF (F2)

To access the configuration settings.
Refer to "6 Configuring".

RESUM (F4)

To resume the last used and stored task. This is a recommended feature when using Advanced mode.

DATA (F5) (for GPS900 receivers)

To view/edit the road data in the road job.
Refer to "9 Viewing and Editing the Design Data".

CSYS (F6)

To change the current co-ordinate system.

Field	Description of Field
Coord System	Output. The active coordinate system. Use CSYS (F6) to change the coordinate system. Road jobs are defined in local grid coordinates. The right coordinate system must be chosen for the road job.

Field	Description of Field
Codelist	Choicelist. The active codelist. All codelists from Main Menu: Manage...\Codelists can be selected.
Config Set (for GPS1200 receivers)	Choicelist. The active configuration set. All configuration sets from Main Menu: Manage...\Configuration Sets can be selected.
Antenna (for GPS1200 receivers)	Choicelist. The antenna currently set in the selected configuration set. All antennas from Main Menu: Manage...\Antennas may be selected.

Positioning the TPS

This screen shows the following:

To select the coordinate system, codelist, configuration set and reflector for the survey.

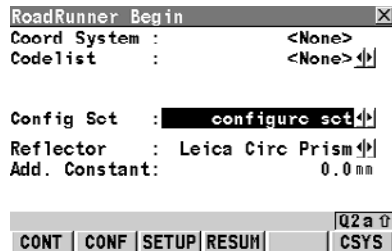

CONT (F1)

To continue to the next screen.

CONF (F2)

To access the configuration settings.
Refer to "6 Configuring".

SETUP (F3)

To set up an instrument station by determining the station coordinates and orienting the horizontal circle.

RESUM (F4)

To resume the last used and stored task. This is a recommended feature when using Advanced mode.

CSYS (F6)

To change the current co-ordinate system.

Field	Description of Field
Coord System	Output. The active coordinate system. Use CSYS (F6) to change the coordinate system. Road jobs are defined in local grid coordinates. The right coordinate system must be chosen for the road job.
Codelist	Choicelist. The active codelist. All codelists from Main Menu: Manage...\Codelists can be selected.
Config Set	Choicelist. The active configuration set. All configuration sets from Main Menu: Manage...\Configuration Sets can be selected.
Reflector	Choicelist. The reflector currently set in the selected configuration set. All reflectors from Main Menu: Manage...\Reflectors may be selected.
Add. Constant	Output. The additive constant stored with the chosen reflector.

2 Step 2 - RoadRunner Setup

Accessing the screens

Press CONT (F1) on the RoadRunner Begin screen.

RoadRunner Setup

This screen shows the following:

An overview of the setup information selected for the survey.

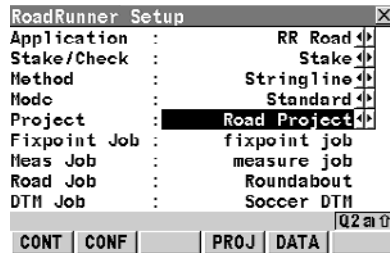

CONT (F1)

To continue to the next screen.

CONF (F2)

To access the configuration settings.
Refer to "6 Configuring".

PROJ (F4)

To edit the currently selected project.
Refer to "7 Managing the Project".

DATA (F5)

To view/edit the road data in the road job.
Refer to "9 Viewing and Editing the Design Data".

SHIFT METHD (F2)

To show/hide the relevant stake/check methods.

Field	Description of Field
Application	To select the relevant program. This field lists all of the programs that have been loaded into the Road-Runner group. Ensure that RR Road is selected.

This screenshot is similar to the one above, but the "Application" field is now set to "RR Road" and is highlighted. The "Stake/Check" field is now "RR Tunnel" and the "Method" field is "RR Rail".

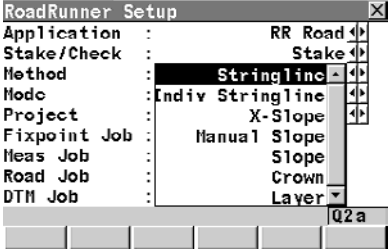
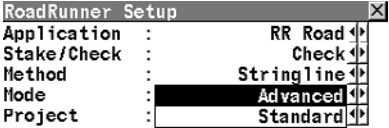
Field	Description of Field
Stake/Check	To select either Stake or Check for the survey. 
Method	To select the relevant method for the survey. All stake/check methods are listed. This list can be configured, so that only the relevant methods for the survey are shown. 
Mode	To select either Standard mode or Advanced mode 
Project	To select the relevant project for the survey.
Fixpoint Job	The fixpoint job, as defined by the project.
Meas Job	The measure job, as defined by the project.

Field	Description of Field
Road Job	The road job, as defined by the project.
DTM (Digital Terrain Model) Job	The DTM job, as defined by the project.

Displaying the methods

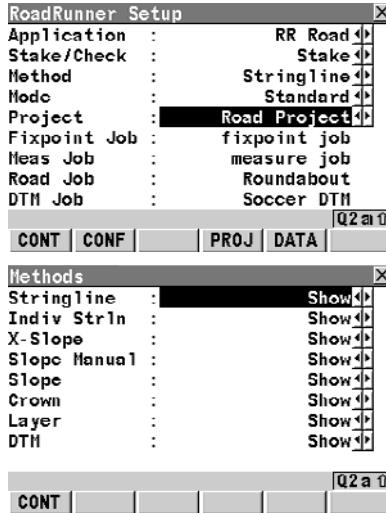

- 1 Press SHIFT METHD (F2) to show/hide the relevant stake/check methods.
- 2 Choose to display only those methods which will be used for the survey. These settings can always be changed later. These settings apply only to RR Road and not to RR Tunnel or RR Rail. These settings will apply to both Stake and Check.

Describing the methods

Field	Description of Field
Stringline	For Stake or Check. To stake/check any type of line, for example a centre line or kerb.
Individual Stringline	For Stake or Check. Similar to the previous method when staking/checking any line of a layer. With this method, no centre line needs to be defined for the layer. The stake/check is therefore always in relation to the chainage of the line itself and not the centre line of the layer.
X-Slope	For Stake or Check. To stake/check a X-slope defined by the road design.
Manual Slope	For Stake or Check. To stake/check a manually defined slope relative to an existing centre line.
Slope	For Stake or Check. To stake/check a slope defined by the 3D road design.
Crown	For Stake or Check. To stake/check a road crown defined by the road design.
Layer	For Stake or Check. To stake/check a layer surface defined by the road design.
DTM (Digital Terrain Model)	For Check only. To checks a DTM surface.

Comparing the modes

RoadRunner may be operated in two modes - Standard mode and Advanced mode.

Feature	Standard	Advanced
Touch screen functionality This is supported in all screens, except in displays with graphics.	✓	✓
Resuming a project It is possible to resume an existing project quickly and conveniently		✓
Displaying/Hiding the stake/check methods RoadRunner can be configured so that only those stake/check methods which are relevant to the user are displayed.	✓	✓
Selecting layers and stringlines during a survey Layers and stringlines can be easily and quickly selected while staking and checking.	✓	
Working with tasks User defined tasks are generated for each stringline when staking and checking. These tasks may always be edited and deleted.		✓
Shifting a stringline (related to a task) It is possible to enter horizontal and/or vertical shifts for stringlines.		✓
Entering chainage limits for a stringline (related to a task) It is possible to enter min. and max. chainages for a stringline.		✓
Staking a stringline in 2D/3D (related to a task) It is possible to stake a stringline in either 2D (X,Y) or 3D (X,Y,Z).	3D only	✓

Standard mode

For standard mode, ensure that Mode=Standard is set in RoadRunner Setup.

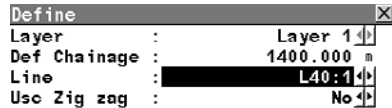

Setting the definitions for the survey

- All of the road element definitions for a survey are available in the Define page.

Working with the Define page

- This is the page which is displayed before starting a stake/check survey in Standard mode.
- The layers and stringlines contained in the active road job can be selected from this page. These elements, combined with other settings on this page can easily be changed during the survey.

Advanced mode

For advanced mode, ensure that Mode=Advanced is set in RoadRunner Setup.

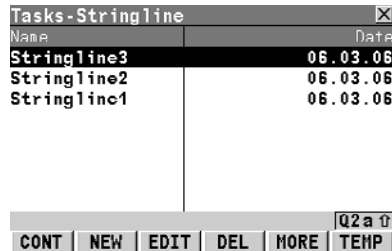

Setting the definitions for the survey

- All of the road element definitions for a survey are available from tasks, which are created and edited using the Selection Wizard.

Working with Tasks

- Tasks are an integral part of all stake/check surveys in Advanced mode.
- The layers and stringlines contained in the active road job are selected from tasks. A task is created for each stringline which is required for the survey. These elements, combined with other definitions can easily be changed during a survey.

3

Step 3 - Working in Standard mode

3.1

An Overview of the Define Page

Accessing the screens

Press CONT (F1) on the RoadRunner Setup screen (using Standard mode).

The Define page

This screen shows the following:

Layers and stringlines contained in the active road job can be selected from this page. These elements, combined with other settings on the page can easily be changed during the survey

```

Define
Layer      :      Layer 1
Def Chainage :      1400.000
Line       :      L40:1
Use Zig zag :      No
  
```

```

CONT
  
```

CONT (F1)

To continue to the next screen.

SHIFT CONF (F2)

To access the configuration settings.
Refer to "6 Configuring".



Refer to "2 Step 2 - RoadRunner Setup" for further details on Standard mode.

3.2

Selecting Layers and Stringlines

Layers and Stringlines

In Standard mode the layers and stringlines are selected from the Define screen.

Selecting a layer

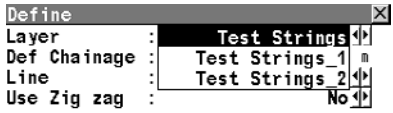
Screen	Description
 <p>Define [X] Layer : Test Strings [v] Def Chainage : Test Strings_1 m Line : Test Strings_2 [v] Use Zig zag : No [v]</p>	Layers can be selected from the choicelist. The choicelist can only be opened when more than one layer is contained in the active road job.

Selecting a stringline

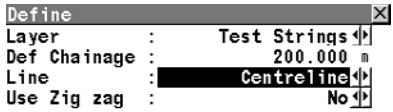
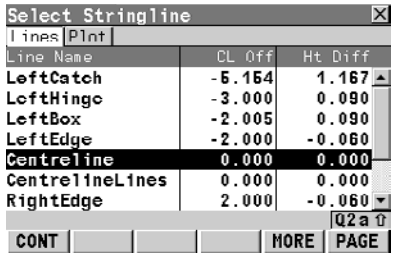
Screen	Step	Description
 <p>Define [X] Layer : Test Strings [v] Def Chainage : 200.000 m Line : Centreline [v] Use Zig zag : No [v]</p>	1	Click on the choicelist containing the stringlines. A line can then be selected from either: 2a) the Lines page, or 2b) the Plot page.
 <p>Select Stringline [X] Lines Plot Line Name CL Off Ht Diff LeftCatch -5.154 1.167 LeftHinge -3.000 0.090 LeftBox -2.005 0.090 LeftEdge -2.000 -0.060 Centreline 0.000 0.000 CentrelineLines 0.000 0.000 RightEdge 2.000 -0.060 [Q2 a ↑] CONT [] [] [] MORE PAGE</p>	2a	Selecting a stringline from the Lines page: Line Name Names of all stringlines in the selected layer. CL Off Offset from the centre line of the selected layer at the current chainage. Ht Diff (Press MORE (F5) to switch this column) Height difference of the stringline to the centre line at the current chainage.

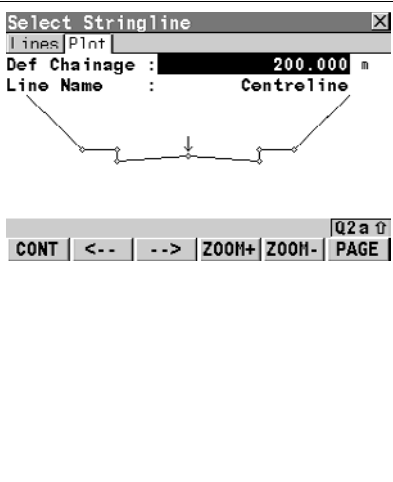
Screen	Step Description
	<p>Height (Press MORE (F5) to switch this column) Absolute height of the stringline at the current chainage.</p>
	<p>2b Selecting a stringline from the Plot page:</p> <p><-- (F2) To change to the previous object.</p> <p>--> (F3) To change to the following object.</p> <p>ZOOM+ (F4) To zoom in at the highlighted object.</p> <p>ZOOM- (F5) To zoom out from the highlighted object.</p> <p>SHIFT FIT (F3) To view the whole X-section.</p> <p>SHIFT INIT (F5) To force a re-calculation of all values.</p>

3.3

The Define Page for Stringlines

Using this Define page for a stake or check survey

For this method, ensure that Method=Stringline is set in RoadRunner Setup.

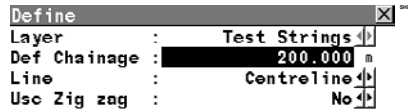

Define

Layer : Test Strings

Def Chainage : 200.000 m

Line : Centreline

Use Zig zag : No



CONT

Q2 a m

CONT (F1)

To continue to the next screen.

SHIFT CONF (F2)

To access the configuration settings.
Refer to "6 Configuring".

Field	Description of Field
Layer	Choicelist. To select a layer in the active road job.
Def Chainage (for Stake) Chainage (for Check)	User Input. To define a chainage for the stake/check survey. The chainage can range between the start chainage and the end chainage.
Line	Choicelist. To select a stringline.
Use Zig zag	Choicelist. Yes or No . To stake/check points on the left/right side of the centre line in one process. Refer to "4.11 The Zig Zag Mode" for details.

3.4 The Define Page for Individual Stringlines

Using this Define page for a stake or check survey

For this method, ensure that Method=Indiv Stringline is set in RoadRunner Setup.

Define	
Layer :	Test Strings
Line :	Centre line
Use Zig zag :	No

CONT (F1)

To continue to the next screen.

SHIFT CONF (F2)

To access the configuration settings.
Refer to "6 Configuring".

CONT						Q2 a ↑
------	--	--	--	--	--	--------

Field	Description of Field
Layer	Choicelist. To select a layer in the active road job.
Line	Choicelist. To select a stringline.
Use Zig zag	Choicelist. Yes or No . To stake/check points on the left/right side of the centre line in one process. Refer to "4.11 The Zig Zag Mode" for details.

3.5

The Define Page for Cross Slopes

Using this Define page for a stake or check survey

For this method, ensure that Method=X-Slope is set in RoadRunner Setup.

The screenshot shows a 'Define' dialog box with the following fields and values:

Layer :	Test Strings
Def Chainage :	200.000 m
Left Strln :	Centreline
Right Strln :	CentrelineLines
Reference Line:	Left Strln
Use Zig zag :	No

The screenshot shows a button labeled 'CONT' with a small icon to its right.

CONT (F1)

To continue to the next screen.

SHIFT CONF (F2)

To access the configuration settings. Refer to "6 Configuring".

Field	Description of Field
Layer	Choicelist. To select a layer in the active road job.
Def Chainage (for Stake) Chainage (for Check)	User Input. The values are limited to the start chainage and end chainage.
Left Strln	Choicelist. The name of the left stringline defining the X-slope.
Right Strln	Output. The name of the right stringline defining the X-slope.
Reference Line	Choicelist. Left Strln or Right Strln . To select one of the stringlines to be used as the reference line.
Use Zig zag	Choicelist. Yes or No . To stake/check points on the left/right side of the centre line in one process. Refer to "4.11 The Zig Zag Mode" for details.

3.6 The Define Page for Manual Slopes

Using this Define page for a stake or check survey

For this method, ensure that Method=Manual Slope is set in RoadRunner Setup.

Define

Layer : Test Strings

Def Chainage : 200.000 m

Hng Reference: Centreline

Hinge Type : Relative

Def Hng Off : 0.000 m

Def Hng HtD : 0.000 m

Slope Type : Cut Right

Slope Ratio : 2:1 hv

Q2 a ↑

CONT SLOPE

CONT (F1)

To continue to the next screen.

SLOPE (F2)

To define the slope parameters.

SHIFT CONF (F2)

To access the configuration settings.
Refer to "6 Configuring".

Field	Description of Field
Layer	Choicelist. To select a layer in the active road job.
Def Chainage (for Stake) Chainage (for Check)	User Input. The values are limited to the start chainage and end chainage.
Hng Reference	Choicelist. To select the hinge point of the slope.
Hinge Type	Choicelist. Relative or Absolute . To select the vertical offset type for the hinge point.
Def Hng Off	User Input. The horizontal offset of the hinge point from the centre line/reference line.
Def Hng HtD	User Input. The height difference of the hinge point from the centre line/reference line. This field is visible if Hinge Type=Relative

Field	Description of Field
Def Hng Elev	User Input. The elevation of the hinge point (absolute height). This field is visible if Hinge Type=Absolute
Slope Type	<p>Choiclist. Cut Right/Left or Fill Right/Left. Differentiates if the defined slope is a cut/fill and left/right.</p> <div data-bbox="954 344 1385 568" data-label="Diagram"> </div> <p>RR12_079</p>
Slope Ratio	Defines the ratio of the slope. The format of Slope Ratio depends on the settings chosen in RoadRunner Project Configuration for Slope Format.

3.7 The Define Page for Design Slopes

Using this Define page for a stake or check survey

For this method, ensure that Method=Slope is set in RoadRunner Setup.

```

Define
Layer      : Test Strings
Def Chainage : 200.000
Left StrIn  : Centreline
Right StrIn : CentrelineLines
Hinge      : Left StrIn
  
```

```

CONT | SLOPE |
  
```

CONT (F1)

To continue to the next screen.

SLOPE (F2)

To define the slope parameters.

SHIFT CONF (F2)

To access the configuration settings.
Refer to "6 Configuring".

Field	Description of Field
Layer	Choicelist. To select a layer in the active road job.
Def Chainage (for Stake) Chainage (for Check)	User Input. The values are limited to the start chainage and end chainage.
Left StrIn	Choicelist. The name of the left stringline defining the slope.
Right StrIn	Output. The name of the right stringline defining the slope.
Hinge	Choicelist. Left StrIn or Right StrIn . To select the hinge point of the slope.

3.8

The Define Page for Crowns

Using this Define page for a stake or check survey

For this method, ensure that Method=Crown is set in RoadRunner Setup.

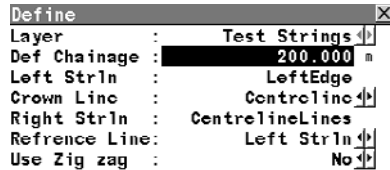

CONT (F1)

To continue to the next screen.

SHIFT CONF (F2)

To access the configuration settings.
Refer to "6 Configuring".

Field	Description of Field
Layer	Choicelist. To select a layer in the active road job.
Def Chainage (for Stake) Chainage (for Check)	User Input. The values are limited to the start chainage and end chainage.
Left StrIn	Output. To select the left stringline defining the X-slope.
Crown Line	Choicelist. To select the common stringline between the left X-slope and right X-slope.
Right StrIn	Output. To select the right stringline defining the X-slope.
Reference Line	Choicelist. Left StrIn or Right StrIn . To select one of the stringlines to be used as the reference line.

Field	Description of Field
Use Zig Zag	Choicelist. Yes or No . To stake/check points on the left/right side of the centre line in one process. Refer to "4.11 The Zig Zag Mode" for details.

3.9

The Define Page for Layers

Using this Define page for a stake or check survey

For this method, ensure that Method=Layer is set in RoadRunner Setup.

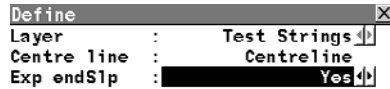

Define

Layer : Test Strings

Centre line : Centreline

Exp endSlp : Yes



CONT

CONT (F1)

To continue to the next screen.

SHIFT CONF (F2)

To access the configuration settings.
Refer to "6 Configuring".

Field	Description of Field
Layer	Choicelist. To select a layer in the active road job.
Centre line	Output. Active centre line of the selected layer.
Exp endSlp	Choicelist. Yes or No . To expand the left most and right most end slopes of the design.

3.10

The Define Page for Digital Terrain Models (DTM)

Using this Define page for a check survey (only applicable to check surveys)

For this method, ensure that Method=DTM is set in RoadRunner Setup

```
Define
DTM      :      Existing
#Triangles :      172
```

```
CONT
```

CONT (F1)

To continue to the next screen.

SHIFT CONF (F2)

To access the configuration settings.
Refer to "6 Configuring".

Field	Description of Field
DTM	Choicelist. A list of all DTM surfaces available in the selected DTM job.
#Triangles	Output. Number of triangles the selected DTM consists of.

4

Step 3 - Working in Advanced mode

4.1

An Overview of Tasks

Accessing the screens

Press CONT (F1) on the RoadRunner Setup screen (using Advanced mode).

Task management

This screen shows the following:

In order to stake/check a road, a task needs to be created or selected. A task is created by using the Selection Wizard. A task is selected from Task Management. The task defines which road is to be staked/checked and defines any shifts that are to be used during the survey. This screen shows a list of all existing tasks stored with the selected project.

Tasks-Stringline	
Name	Date
Stringline3	06.03.06
Stringline2	06.03.06
Stringline1	06.03.06

CONT	NEW	EDIT	DEL	MORE	TEMP
------	-----	------	-----	------	------

CONT (F1)

To continue to the next screen.

NEW (F2)

To create a new task with the Selection Wizard.

EDIT (F3)

To edit an existing task with the Selection Wizard.

DEL (F4)

To delete an existing task.

MORE (F5)

To toggle between the task date and task time.

TEMP (F6)

To create a temporary task with the Selection Wizard. This task is identical to any other task but is not stored for later use.

SHIFT HOME (F2)

To go to the top of the list.

SHIFT END (F3)

To go to the end of the list.

SHIFT TIME/NAME (F5)

To sort the list by time or name.

Column	Description of column
Name	The name of the working task.
The following columns/values can be toggled, by using the MORE (F5) softkey:	
Date	The creation date of the working task.
Time	The creation time of the working task.



Refer to "2 Step 2 - RoadRunner Setup" for further details on Advanced mode.

4.2 Selecting Layers and Stringlines

Layers and Stringlines

In Advanced mode a task is created, edited or selected in order to stake/check elements of a road. The task defines which road is to be staked/checked, including which layers and stringlines are to be used.

Selecting a layer

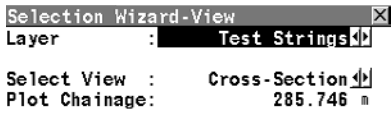
Screen	Description
 <p>Selection Wizard-View</p> <p>Layer : Test Strings</p> <p>Select View : Cross-Section</p> <p>Plot Chainage: 285.746 m</p>	<p>Layers can be selected from the choicelist in the View screen of the Selection Wizard. The choicelist can only be opened when more then one layer is contained in the active road job.</p>

Selecting a stringline

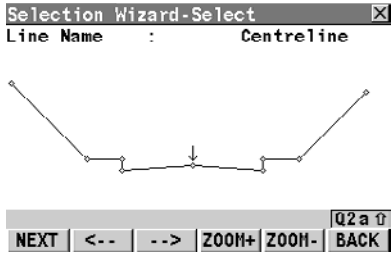
Screen	Description
 <p>Selection Wizard-Select</p> <p>Line Name : Centreline</p> <p>NEXT <-- --> ZOOM+ ZOOM- BACK</p> <p>Q2 a ↑</p>	<p>Stringlines can be selected from the Select screen of the Selection Wizard.</p>

4.3

Creating/Editing Tasks with the Selection Wizard

4.3.1

Overview

General

The element to stake out or check is selected at the start of the stake out and check process. This selection is made at the same time as the definition of the parameters for the stake out/check. The selection wizard guides you through the process of selecting and defining the elements to stake out or check. The selected element to stake out/check and all the parameters defined are stored as a new working task. Tasks created with the selection wizard are stored as part of the project and may be called up again.

Two types of tasks

- RoadRunner distinguishes between two types of tasks:
 - Persisted tasks, these tasks are stored as part of the project and can be re-called. Persisted tasks should be created if you will have to come back to complete this stake/check survey.
 - Temporary tasks, these tasks are not persisted. They are used if you have to stake/check only a few points.
 - Temporary tasks will not show up in Task Management and cannot be re-called.
-

Description

The basic steps and dialogs are common for every selection although, depending on the chosen settings, certain screens of the wizard are skipped.

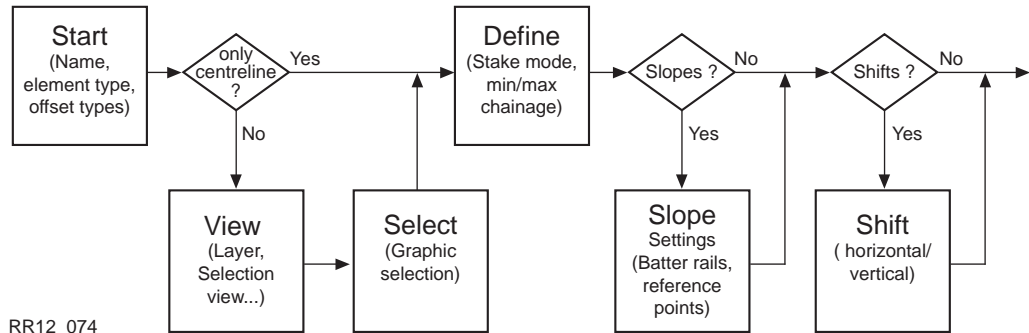

IF the task is to	THEN
step from one screen of the wizard to the next one	NEXT (F1).
to return to the previous wizard screen	BACK (F2).
exits the wizard on the last screen of the wizard	FINSH (F1).

4.3.2

Selection Wizard - Start Screen

Description

Selection Wizard-Start is the first screen accessed by the selection wizard.

Access

The screen is accessed as part of the selection wizard.

RR

Selection Wizard-Start

Selection Wizard-Start

Task Type : Stringline

Task Name : Stringline1

Use Zig zag : No

Shift Horizt1: None

Shift Vertic1: None

NEXT Q2 a ↑

NEXT (F1)

To move to the next screen of the selection.

Field	Option	Description of Field
Task Type	Centreline	The task type to select. Options will vary depending upon from which stake out/check method the selection wizard is accessed.
	Stringline	Selection of a stringline to be used as centre line.
	Indiv Stringline	Selection of a stringline part of a layer with defined centreline.
	Slope	Selection of a stringline within a layer, independent if a centreline is defined.
	Manual Slope	Selection of a slope.
	Manual Slope	Selection of the centre line for a manual slope.

Field	Option	Description of Field
	X-Slope Crown Layer DTM	Selection of a X-slope. Selection of a road crown. Selection of a design layer. Selection of a DTM/TIN surface.  The list of stake out and check methods is not identical with the available task types. For example, Stringline uses centreline and stringline.
Task Name	User input	The name of the task to be stored.
Use Zig zag	Yes or No	The zig zag mode is used to stake out points on the left and right hand side of the centre line in one process. The zig zag mode is available for stakeout/check methods: <ul style="list-style-type: none"> • Stringline/Indiv Stringline • X-Slope • Road Crown. Refer to "4.11 The Zig Zag Mode" for more information on the zig zag mode.

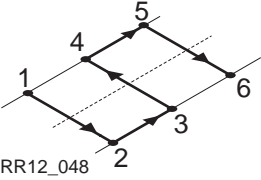
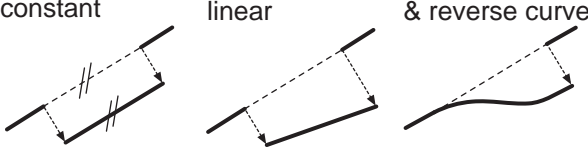
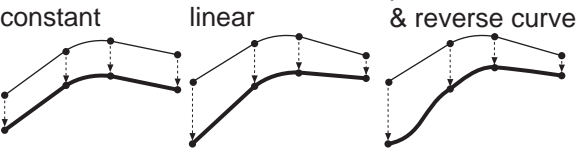
Field	Option	Description of Field
		
Shift Horiztl	None, Linear, Constant, Parabolic or Reverse Curve	<p>Type of horizontal shift applied to the object.</p> <p>constant linear parabolic & reverse curve</p> 
Shift Verticl	None, Linear, Constant, Parabolic or Reverse Curve	<p>Type of vertical shift applied to the object.</p> <p>constant linear parabolic & reverse curve</p> 

Next step

NEXT (F1) to move to the next step of the selection wizard.

4.3.3

Selection Wizard - View Screen

Description

Selection Wizard-View defines the layer and its graphic appearance for the selection.

Access

The screen is accessed as part of the selection wizard.

RR

Selection Wizard-View

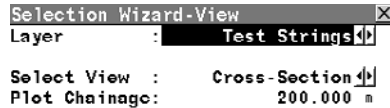
**NEXT (F1)**



To move to the next screen of the selection.



DEFLT (F5)

To reset the **Plot Chainage** to the start chainage of the layer centre line.

BACK (F6)

To move back to the previous screen of the wizard.

Field	Option	Description of Field
Layer	Choicelist	The layer the object to select belongs to.
Select View	Cross-Section	The selection view used for picking the objects. Cross section view of the design data.  The cross section view is available for all working methods.
	Plan	2D plan view of the design data.  The plan view is only available for the working methods Stringline and Individual Stringline.

Field	Option	Description of Field
Plot Chainage	User input	<p>With Select View: Cross-Section, it defines the chainage at which the cross section for the graphical selection is created.</p> <p>With Select View: Plan, it defines the chainage which is to be marked and displayed by a triangle. This allows easier user orientation within a project.</p> <p> Plot Chainage is only used for Select View: Cross Section and the working method Individual Stringline.</p>
Plot Step	User input	<p>To define a chainage increment. This is the amount by which the Plot Chainage is to be incremented and updated on the screen display.</p> <p> Plot Step is only used for Select View: Cross Section and the working method Individual Stringline.</p>

Next step

NEXT (F1) to move to the next step of the selection.

**RR
Selection Wizard-DTM**

Unlike all other objects, DTM's are selected by name.

4.3.4

Selection Wizard - Select Screen

Description

This screen allows the object to be used for the chosen task to be selected. Depending on the chosen **Selection View** on the previous screen, this screen shows either a plan or a cross section view.

Access

The screen is accessed as part of the selection wizard.

RR

Selection Wizard-Select cross section view

The graphic shown is a cross section view of the layer selected in the previous step of the selection wizard. The name of the stringline/s defining the highlighted element are shown at the top of the screen.

**NEXT (F1)**

To move to the next screen of the selection.

<-- (F2)

To change to the previous object.

--> (F3)

To change to the following object.

ZOOM+ (F4)

To zoom in at the position of the current highlighted object.

ZOOM- (F5)

To zoom out at the position of the current highlighted object.

BACK (F6)

To move back to the previous screen of the wizard.

SHIFT FIT (F3)

To view the whole X-section.

Next step

NEXT (F1) to move to the next step of the selection wizard.

RR Selection Wizard-Select plan view

Description

The graphic shown is a plan view of the layer selected in the previous step of the Selection Wizard. The name of the stringline/s defining the highlighted element are shown at the top of the screen. For easier orientation within a project, the plan view includes a triangle which represents the **Plot Chainage**, as selected in the previous screen of the Selection Wizard. This selection method is available for the individual stringline work method.

Screen



NEXT (F1)

To move to the next screen of the selection.

<-- (F2)

To change to the previous object.

--> (F3)

To change to the following object.

ZOOM+ (F4)

To zoom in at the position of the current highlighted object.

ZOOM- (F5)

To zoom out at the position of the current highlighted object.

BACK (F6)

To move back to the previous screen of the wizard.

SHIFT CH+ (F2)

To increment the **Plot Chainage** by the **Plot Step**.

SHIFT FIT (F3)

To view the whole alignment.

SHIFT CENTR (F4)

To centre the plot at the selected element.

SHIFT LIST (F5)

To list the plot at the selected element.

Next step

NEXT (F1) to move to the next step of the selection wizard.

4.3.5

Selection Wizard - Define Screen

Description

RR Selection Wizard-Define allows parameters relevant to the task to be defined.

RR Selection Wizard-Define varies for each of the following elements:

- Stringlines and centre lines
- X-slopes and road crowns
- Slopes
- Layers

RR Selection Wizard-Define does not exist for DTM's.

Access

The screen is accessed as part of the selection wizard.

RR

Selection Wizard-Define for stringlines and individual stringlines

Selection Wizard-Define

Line Name : Centreline

Stake Mode : 3D

Use Min/Max : Yes

Min Chainage : 100.000 m

Max Chainage : 285.746 m

FINISH DEFLT BACK

Field	Option	Description of Field
Line Name	Output	The name of the selected stringline.
Stake Mode	3D	The stake out mode used for the selected object. Full 3D stake out or check of the selected object.

NEXT (F1)

To move to the next screen of the selection.

DEFLT (F5)

To reset the **Min Chainage** and **Max Chainage** to the start/end chainage of the layer centre line.

BACK (F6)

To move back to the previous screen of the wizard.

Field	Option	Description of Field
	2D	Stake out or check of the selected object in position only.
Use Min/Max	Yes or No	Define a maximum and minimum working chainage. Refer to "4.12 Chainage Range" for more information.
Min Chainage	User input	Minimum chainage of the chainage range. Refer to "4.12 Chainage Range" for more information.
Max Chainage	User input	Maximum chainage of the chainage range. Refer to "4.12 Chainage Range" for more information.

Next step

IF the task is to	THEN
move to the next step of the selection wizard	NEXT (F1).
to confirm all steps of the selection wizard and exit it, if it is the last screen of the selection wizard	FINSH (F1).

RR Selection Wizard-Define for X-slopes

```

Selection Wizard-Define
Left StrLn  :      Centreline
Right StrLn :      CentrelineLines
Reference Line:      Left StrLn
Use Min/Max :      Yes
Min Chainage :      100.000 m
Max Chainage :      285.748 m
  
```

```

FINSH |  |  |  | Q2 a |
DEFLT | BACK |
  
```

Field	Option	Description of Field
Left Strgl	Output	The name of the left stringline defining the X-slope.
Right Strgl	Output	The name of the right stringline defining the X-slope.
Refrence Line	Left Strgl or Right Strgl	The stringline the stake out of the X-slope is relative to.
Use Min/Max	Yes or No	Define a maximum and minimum working chainage. Refer to "4.12 Chainage Range" for more information.
Min Chainage	User input	Minimum chainage of the chainage range. Refer to "4.12 Chainage Range" for more information.
Max Chainage	User input	Maximum chainage of the chainage range. Refer to "4.12 Chainage Range" for more information.

NEXT (F1)

To move to the next screen of the selection.

DEFLT (F1)

To reset the **Min Chainage** and **Max Chainage** to the start/end chainage of the layer centre line.

BACK (F6)

To move back to the previous screen of the wizard.

Next step

IF the task is to	THEN
move to the next step of the selection wizard	NEXT (F1).
to confirm all steps of the selection wizard and exit it, if it is the last screen of the selection wizard	FINSH (F1).

**RR
Selection Wizard-Define
for slopes**

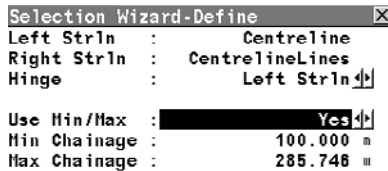

NEXT (F1)

To move to the next screen of the selection.

DEFLT (F5)

To reset the **Min Chainage** and **Max Chainage** to the start/end chainage of the layer centre line.

BACK (F6)

To move back to the previous screen of the wizard.

Field	Option	Description of Field
Left Strgl	Output	Name of the slopes left stringline.
Right Strgl	Output	Name of the slopes right stringline.
Hinge	Left Strgl or Right Strgl	The stringline of the slope on which the hinge point lies.
Use Min/Max	Yes or No	Define a maximum and minimum working chainage. Refer to "4.12 Chainage Range" for more information.
Min Chainage	User input	Minimum chainage of the chainage range. Refer to "4.12 Chainage Range" for more information.

Field	Option	Description of Field
Max Chainage	User input	Maximum chainage of the chainage range. Refer to "4.12 Chainage Range" for more information.

Next step

IF the task is to	THEN
move to the next step of the selection wizard	NEXT (F1).
to confirm all steps of the selection wizard and exit it, if it is the last screen of the selection wizard	FINSH (F1).

RR Selection Wizard-Define for crowns

RR Selection Wizard-Define of the selection wizard for crowns is identical to **RR Selection Wizard-Define** for X-slopes, the difference being the behavior of the reference line. The left most and right most line of the two X-slopes may be chosen as the reference line. The stake offsets and stake height difference applied to the road crown are relative to this reference line. For the second X-slope of the road crown, stake offsets/height difference are added symmetrically.

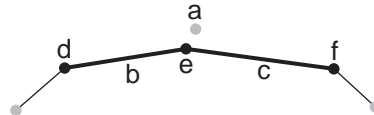

RR12_078

- a) Centre line
- b) Left X-slope of the road crown
- c) Right X-slope of the road crown
- d) **Left Strgl**, left most stringline
- e) **Mid Strgl**, mid stringline
- f) **Right Strgl**, right most stringline

RR
Selection Wizard-Define
for layers

```

Selection Wizard-Define
Centre line : Centreline
Exp endSlp : Yes
Use Min/Max : Yes
Min Chainage : 100.000 m
Max Chainage : 285.748 m
    
```

```

FINSH DEFLT BACK
    
```

NEXT (F1)

To move to the next screen of the selection.

DEFLT (F5)

To reset the **Min Chainage** and **Max Chainage** to the start/end chainage of the layer centre line.

BACK (F6)

To move back to the previous screen of the wizard.

Field	Option	Description of Field
Centre-line	Output	Active centre line of the selected layer.
Exp endSlp	Yes No	To expand the left most and right most end slopes of the design. Prolong end slopes of the layer. End-slopes will not be prolonged.
Use Min/Max	Yes or No	Define a maximum and minimum working chainage. Refer to "4.12 Chainage Range" for more information.
Min Chainage	User input	Minimum chainage of the chainage range. Refer to "4.12 Chainage Range" for more information.
Max Chainage	User input	Maximum chainage of the chainage range. Refer to "4.12 Chainage Range" for more information.

Next step

IF the task is to	THEN
move to the next step of the selection wizard	NEXT (F1).
to confirm all steps of the selection wizard and exit it, if it is the last screen of the selection wizard	FINSH (F1).

RR Selection Wizard-Define for DTM's

```
Selection Wizard-Define
DTM : Existing
#Triangles : 172
```

NEXT (F1)

To move to the next screen of the selection.

BACK (F6)

To move back to the previous screen of the wizard.

```
Q2 a
FINSH | | | | | BACK
```

Field	Option	Description of Field
DTM	Choicelist	A list of all DTM surfaces available in the selected DTM job.
# Triangles	Output	Number of triangles the selected DTM consists of.

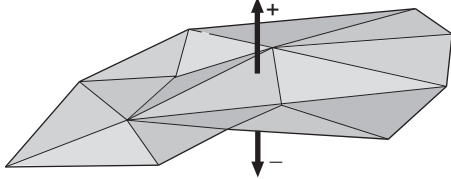
Field	Option	Description of Field
Shift Vertical	User input	<p>Vertical shift for the DTM. A positive shift moves the DTM up. A negative shift moves it down.</p>  <p>RR12_051</p>

Next step

IF the task is to	THEN
move to the next step of the selection wizard	NEXT (F1).
to confirm all steps of the selection wizard and exit it, if it is the last screen of the selection wizard	FINSH (F1).

4.3.6

Selection Wizard - Slope Screen

Description

Depending on the **Slope method** chosen in **RR Road Configuration, General** page the following screens appear.

IF	THEN
Slope method: None	<ul style="list-style-type: none">• No screen for slope stake definition is available.
Slope method: Batter rail	<ul style="list-style-type: none">• The screen to define batter rails for cut and fill slopes is used.• Refer to " RR Selection Wizard-Slope batter rails screen" for information on defining the batter rail.
Slope method: Refpoint	<ul style="list-style-type: none">• The screen to define the reference point is used.• Refer to " RR Selection Wizard-Slope reference peg screen" for information on defining the reference peg.
Slope method: Ref Batter	<ul style="list-style-type: none">• The screen to define the reference batter is used.• Refer to " RR Selection Wizard-Slope reference batter screen" for information on defining the batter rail.

Access

The screen is accessed as part of the Selection Wizard.

RR
Selection Wizard-Slope
batter rails screen

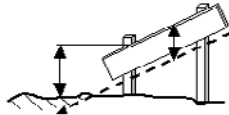
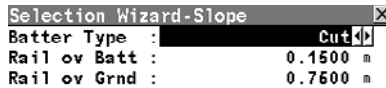

NEXT (F1)

To confirm all steps of the wizard and exit the selection wizard.

BACK (F6)

To move back to the previous screen of the wizard.

Field	Option	Description of Field
Batter Type	Cut or Fill	Toggle between the definition for cut and fill batter rails.
Rail ov Batt	User input	The height of the rail over the slope. Represents the "traveller" height if working with "travellers".
Rail ov Grnd	User input	The height of the rail over ground. Used to make sure that the stake used is long enough.

RR
Selection Wizard-Slope
reference peg screen

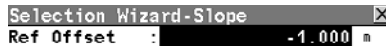

NEXT (F1)

To confirm all steps of the wizard and exit the selection wizard.

BACK (F6)

To move back to the previous screen of the wizard.

Field	Option	Description of Field
Ref Offset	User input	<p>The horizontal offset of the reference point from the catch point.</p> <p> For Ref Offset the sign depends on the side of the centreline. In the direction of increasing chainage the offset is negative for the left side. In the direction of increasing chainage the offset is positive for the right side.</p>

RR
Selection Wizard-Slope
reference batter screen

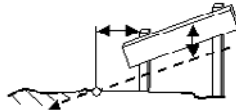

NEXT (F1)

To confirm all steps of the wizard and exit the selection wizard.

BACK (F6)

To move back to the previous screen of the wizard.

Field	Option	Description of Field
Ref Offset	User input	The horizontal offset of the reference point from the catch point.
Traveller Ht	User input	The "Traveller" height. Height of the rail above the slope.

Next step

IF the task is to	THEN
move to the next step of the selection wizard	NEXT (F1).
to confirm all steps of the selection wizard and exit it, if it is the last screen of the selection wizard	FINSH (F1).

4.3.7

Selection Wizard - Shift Screen

Description

Horizontal and vertical shifts can be applied to the selected element. By using these shifts the design can be lifted/lowered and moved horizontally.

Access

These screens of the selection wizard are only accessed if in the first step of the selection wizard in **RR Selection Wizard-Start** the selections are different to **Shift Horiztl: None** or **Shift Verticl: None**. The screen is accessed as part of the selection wizard.

RR

Selection Wizard-Shift

```

Selection Wizard-Shift
Shift Type      : Horiz- Linear
Beg Chainage   : 100.000 m
Beg Shift      : 0.000 m
End Chainage    : 285.746 m
End Shift      : 0.000 m

Before/After   : None
    
```

```

Q2 a ↑
NEXT  BACK
    
```

NEXT (F1)

To move to the next screen of the selection.

BACK (F6)

To move back to the previous screen of the wizard.

Field	Option	Description of Field
Shift Type	Output	Type of shift selected for the object on the first screen of the wizard.
	Horiz- ReCurve	Horizontal reverse curve
	Vert-ReCurve	Vertical reverse curve
		Refer to "12.2 Horizontal and Vertical Shifts" for more information on shifts.
Beg Chainage	User input	Chainage from which on the shift is added.

Field	Option	Description of Field
Beg Shift	User input	Shift of the object at Beg Chainage .
End Chainage	User input	Chainage till which the shift is added.
End Shift	User input	Shift of the object at End Chainage .
Before/After	<p>None</p> <p>Steps</p> <p>Parallel</p>	<p>Defines the object outside of the defined shift range.</p> <p>The object only exists within the defined shift range.</p> <p>Before/after the defined shift range no shift is added.</p> <p>The Beg Shift/End Shift are continued parallel.</p> <p>None Step Parallel</p> <p>RR12_057</p>

Next step

IF the task is to	THEN
move to the next step of the selection wizard	NEXT (F1).
to confirm all steps of the selection wizard and exit it, if it is the last screen of the selection wizard	FINSH (F1).

Define horizontal and/or vertical shift step-by-step

	Description	Refer to chapter
1.	 RR Selection Wizard-Shift is accessed as part of the selection wizard. Depending on the selection for Shift Horiztl , Shift Verticl for the stringline in RR Selection Wizard-Start the next steps vary. <ul style="list-style-type: none"> • Unless Shift Horiztl: None, continue with step 2. • If Shift Horiztl: None, continue with step 3. 	
2.	RR Selection Wizard-Shift Define the horizontal shift.	4.3.7
3.	Depending on the selection for Shift Verticl for the stringline in RR Selection Wizard-Start the next steps vary. <ul style="list-style-type: none"> • Unless Shift Verticl: None, continue with step 4. • If Shift Verticl: None, continue with step 6. 	
4.	Press NEXT (F1)	
5.	RR Selection Wizard-Shift Define the vertical shift.	4.3.7
6.	Continue with the next step of the selection.	

4.4 Selecting Stringlines, Indiv Stringlines or Centrelines

Description

Stringlines are always defined relative to the centre line of the layer. Refer to "11.3 Basic Elements for Road Stake and Check Measurements" for information on stringlines.

Stringline selection step-by-step

	Description	Refer to chapter
1.	<p>RR Selection Wizard-Start</p> <p>Choose Task Type: Stringline</p> <p>Choose Task Type: Centreline.</p> <p>If the road job consists of no other stringlines than one centreline then Task Type: Centreline is fixed.</p> <p>Define Task Name, Use Zig zag and select the type of shifts to add Shift Horiztl and Shift Verticl.</p>	4.3.2
2.	Press NEXT (F1)	
3.	<p>RR Selection Wizard-View</p> <p>Define Select View, Plot Chainage and select the Layer.</p>	4.3.3
4.	Press NEXT (F1)	
5.	RR Selection Wizard-Select	4.3.4
	<-- (F2) and --> (F3) to select the stringline by moving right and left. If Task Type: Centreline the selection is fixed to the centre line of the layer.	
6.	Press NEXT (F1)	
7.	RR Selection Wizard-Define	4.3.5

	Description	Refer to chapter
	Define Stake Mode , Use Min/Max , Min Chainage and Max Chainage	
8.	Depending on the selection for Shift Horiztl and Shift Verticl the next steps vary. <ul style="list-style-type: none"> • If Shift Horiztl: None, Shift Verticl: None continue with step 9. • If Shift Horiztl and Shift Verticl are not set to None, then press NEXT (F1) to define the shifts and then continue with step 9. 	4.3.7
9.	Press FINSH (F1) to confirm all wizard steps and exit the wizard.	

4.5 Selecting X-Slopes

Description

X-slopes consist of two stringlines representing their left and right edge. Refer to "11.3 Basic Elements for Road Stake and Check Measurements" for information on X-slopes.

X-slope selection step-by-step

	Description	Refer to chapter
1.	RR Selection Wizard-Start	4.3.2
	Choose Task Type: X-Slope .	
	Define Task Name, Use Zig zag and select the type of shifts to add Shift Horiztl and Shift Verticl .	
2.	Press NEXT (F1)	
3.	RR Selection Wizard-View Select the Layer and Plot Chainage . Select View: Cross-Section is fixed.	4.3.3
4.	Press NEXT (F1)	
5.	RR Selection Wizard-Select <-- (F2) and --> (F3) to select the X-slope by moving right and left.	4.3.4
6.	Press NEXT (F1)	
7.	RR Selection Wizard-Define Define Refrence Line, Use Min/Max, Min Chainage and Max Chainage .	4.3.5
8.	Depending on the selection for Shift Horiztl and Shift Verticl the next steps vary.	4.3.7

	Description	Refer to chapter
	<ul style="list-style-type: none">• If Shift Horiztl: None, Shift Verticl: None continue with step 9.• If Shift Horiztl and Shift Verticl are not set to None, then press NEXT (F1) to define the shifts and then continue with step 9.	
9.	Press FINSH (F1) to confirm all wizard steps and exit the wizard.	

4.6 Selecting Slopes

Description



Slopes consist of two stringlines, the hinge point lies on one of the stringlines.

To avoid errors and minimise the number of keystrokes, the vertex of the slope closer to the centreline is chosen as default for the hinge point during the definition in the Selection Wizard.

Slope selection step-by-step

	Description	Refer to chapter
1.	RR Selection Wizard-Start Choose Task Type: Slope .	4.3.2
	Define Task Name and select the type of shifts to add Shift Horiztl and Shift Verticl . Zig zag mode can not be used with slopes.	
2.	Press NEXT (F1)	
3.	RR Selection Wizard-View Choose the Layer and Plot Chainage . Select View: Cross-Section is fixed.	4.3.3
4.	Press NEXT (F1)	
5.	RR Selection Wizard-Select <-- (F2) and --> (F3) to select the slope by moving right and left.	4.3.4
6.	Press NEXT (F1)	

	Description	Refer to chapter
7.	RR Selection Wizard-Define Define Hinge , Use Min/Max , Min Chainage and Max Chainag .	4.3.5
8.	Press NEXT (F1)	
9.	Depending on Slope method chosen in RR Project Configuration, General the next steps vary. <ul style="list-style-type: none"> • If Slope method: None, continue with step 10. • If Slope method: Batter rails, continue with paragraph "Batter rail definition step-by-step". • If Slope method: Ref Point, continue with paragraph "Reference point definition step-by-step". • If Slope method: Ref Batter, continue with paragraph "Reference point definition step-by-step". 	
10.	Depending on the selection for Shift Horiztl and Shift Verticl the next steps vary. <ul style="list-style-type: none"> • If Shift Horiztl: None, Shift Verticl: None continue with step 11. • If Shift Horiztl and Shift Verticl are not set to None, then press NEXT (F1) to define the shifts and then continue with step 11. 	4.3.7
11.	Press FINSH (F1) to confirm all wizard steps and exit the wizard.	

**Batter rail
definition step-by-step**

	Description	Refer to chapter
1.	Press NEXT (F1)	
2.	RR Selection Wizard-Slope Define Rail ov Batt and Rail ov Grnd.	4.3.6
3.	Press NEXT (F1)	
4.	Depending on the selection for Shift Horiztl and Shift Verticl the next steps vary. <ul style="list-style-type: none"> • If Shift Horiztl: None, Shift Verticl: None continue with step 5. • If Shift Horiztl and Shift Verticl are not set to None, then press NEXT (F1) to define the shifts and then continue with step 5. 	4.3.7
5.	Press FINSH (F1) to confirm all wizard steps and exit the wizard.	

**Reference point
definition step-by-step**

	Description	Refer to chapter
1.	Press NEXT (F1)	
2.	RR Selection Wizard-Slope Define Ref Offset.	4.3.6
3.	Press NEXT (F1)	
4.	Depending on the selection for Shift Horiztl and Shift Verticl the next steps vary. <ul style="list-style-type: none"> • If Shift Horiztl: None, Shift Verticl: None continue with step 5. 	4.3.7

Reference batter
definition step-by-step

	Description	Refer to chapter
	<ul style="list-style-type: none"> If Shift Horiztl and Shift Verticl are not set to None, then press NEXT (F1) to define the shifts and then continue with step 5. 	
5.	Press FINSH (F1) to confirm all wizard steps and exit the wizard.	

	Description	Refer to chapter
1.	Press NEXT (F1)	
2.	RR Selection Wizard-Slope Define Ref Offset and Traveller Height .	4.3.6
3.	Press NEXT (F1)	
4.	Depending on the selected Shift Horiztl and Shift Verticl the next steps will vary. <ul style="list-style-type: none"> If Shift Horiztl: None, Shift Verticl: None continue with step 5. If Shift Horiztl and Shift Verticl are not set to None, then press NEXT (F1) to define the shifts and then continue with step 5. 	4.3.7
5.	Press FINSH (F1) to confirm all wizard steps and exit the wizard.	

4.7 Selecting Manual Slopes

Description

Manual slopes are defined relative to a stringline. The creation of the task is therefore quite similar to the one of a stringline.

Manual slope selection step-by-step

	Description	Refer to chapter
1.	RR Selection Wizard-Start Choose Task Type: Manual Slope .	4.3.2
2.	Define Task Name: and select the type of shifts to add Shift Horiztl: and Shift Verticl. Zig zag mode can not be used with manual slopes.	
3.	Press NEXT (F1)	
4.	RR Selection Wizard-View Define Select View, Plot Chainage and select the Layer:.	4.3.3
5.	Press NEXT (F1)	
6.	RR Selection Wizard-Select The selection is fixed to the centre line of the layer.	4.3.4
7.	Press NEXT (F1)	
8.	RR Selection Wizard-Define Define Use Min/Max:, Min Chainag and Max Chainage Stake Mode: 3D is fixed.	4.3.5

	Description	Refer to chapter
9.	Depending on the selection for Shift Horiztl and Shifts Verticl the next steps vary. <ul style="list-style-type: none">• If Shift Horiztl: None, Shift Verticl: None continue with step 10.• If Shift Horiztl and Shift Verticl are not set to None, then press NEXT (F1) to define the shifts and then continue with step 10.	4.3.7
10.	Press FINSH (F1) to confirm all wizard steps and exit the wizard.	

4.8 Selecting Layers

Description

Layers consist of a various number of stringlines representing the layer surface, for example, one centre line and the right and left edge of the road. Refer to "11.3 Basic Elements for Road Stake and Check Measurements" for information on layers.

Slope selection step-by-step

	Description	Refer to chapter
1.	RR Selection Wizard-Start Choose Task Type: Layer .	4.3.2
2.	Define Task Name and select the type of shifts to add Shift Verticl . No horizontal Shift Horiztl can be added to a layer. Zig zag mode can not be used with slopes.	
3.	Press NEXT (F1)	
4.	RR Selection Wizard-View Choose the Layer and Plot Chainage . Select View: Cross-Section is fixed.	4.3.3
5.	Press NEXT (F1)	
6.	RR Selection Wizard-Select Graphical representation of the selected layer at the defined Plot Chainage .	4.3.4
7.	Press NEXT (F1)	
8.	RR Selection Wizard-Define	4.3.5

	Description	Refer to chapter
	Define Exp endSlp , Use Min/Max , Min Chainage and Max Chainage	
9.	Depending on the selection for Shift Horiztl and Shift Verticl the next steps vary. <ul style="list-style-type: none"> • If Shift Horiztl: None, Shift Verticl: None continue with step 10. • If Shift Horiztl and Shift Verticl are not set to None, then press NEXT (F1) to define the shifts and then continue with step 10. 	4.3.7
10.	Press FINSH (F1) to confirm all wizard steps and exit the wizard.	

4.9 Selecting Digital Terrain Models (DTM)

Description

Unlike all other objects DTM's are not related to a centre line. Therefore it is not necessary to define chainage related settings, and hence, some steps of the selection wizard are skipped. Refer to "11.3 Basic Elements for Road Stake and Check Measurements" for information on DTM's.

DTM selection step-by-step

	Description	Refer to chapter
1.	RR Selection Wizard-Start Choose Task Type: DTM . Define Task Name .	4.3.2
2.	Press NEXT (F1) .	
3.	RR Selection Wizard . Select the DTM and define the vertical shift Shift Vertical .	4.3.3
4.	Press FINSH (F1) to confirm all wizard steps and exit the selection wizard.	

4.10

Selecting Road Crowns

Description

Road crowns consist of two X-slopes. They are a combined stake out of two X-slopes at once. Refer to "11.3 Basic Elements for Road Stake and Check Measurements" for information on road crowns.

Road crown step-by-step

	Description	Refer to chapter
1.	RR Selection Wizard-Start	4.3.2
	Choose Task Type: Crown	
2.	Define Task Name and select the type of shifts to add Shift Horiztl and Shift Verticl . The horizontal shift is added along the X-slope for the defined reference line.	11.4.3
3.	Press NEXT (F1)	
4.	RR Selection Wizard-View Choose the Layer and define the Plot Chainage . Select View: Cross-Section is fixed.	4.3.3
5.	Press NEXT (F1)	
6.	RR Selection Wizard-Select <-- (F2) and --> (F3) to select the crown.	4.3.4
7.	Press NEXT (F1)	
8.	RR Selection Wizard-Select	4.3.5

	Description	Refer to chapter
9.	Define Reference Line , Use Min/Max , Min Chainage and Max Chainage . Only the left most and right most stringline of the crown may be selected as reference line. Stake offsets / height differences are relative to the reference line and symmetric to the middle stringline of the road crown.	
10.	Depending on the selection for Shift Horiztl and Shift Verticl the next steps vary. <ul style="list-style-type: none">• If Shift Horiztl: None, Shift Verticl: None continue with step 10.• If Shift Horiztl and Shift Verticl are not set to None, then press NEXT (F1) to define the shifts and then continue with step 10.	4.3.7 11.4.3
11.	Press FINSH (F1) to confirm all wizard steps and exit the wizard.	

4.11

The Zig Zag Mode

Description

If staking out a street that is defined as a centre line with offsets of 2.5 m left and right, the zig zag mode allows you to toggle between the two lines to stake out.

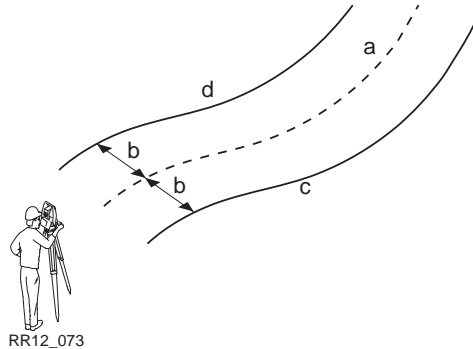

- a) Centre line
- b) Defined **Stake Offset**
- c) Parallel right stringline
- d) Parallel left stringline

The zig zag mode is available for the following stake out/check methods:

Type	Description
Stringline	Toggle between parallel stringline left and right.
X-slope	Toggle between left and right stringline of the X-slope.
Road crown	Toggle between left and right X-slope

RoadRunner automatically detects which side of the centre line is being used and selects the appropriate stringline as a reference.

Auto position with zig zag

When pressing auto position **SHIFT POSIT (F4)** a message box comes up prompting you if either the left or right side should be staked out/checked.

4.12

Chainage Range

Description

The chainage range is chosen during task creation with the selection wizard. By defining a chainage range it is possible to limit which part of the design will be stake out or checked. If the defined chainage range is exceeded during stake out/check a warning appears.

Chainage range fields





The following fields are used for the chainage range definition:

Field	Option	Description
Use Min/Max	No	To define the used chainage range. No chainage range is applied. The whole length of the stringline is used.
	Yes	A chainage range is applied. If the defined range is exceeded a warning appears.  DEFLT (F5) to use the start/end chainage of the centre line as Min Chainage / Max Chainage .
Min Chainage	User input	Minimum chainage of the chainage range.
Max Chainage	User input	Maximum chainage of the chainage range.

5 Step 4 - Measuring

5.1 Staking/Checking the Road - An Overview of the Pages

The Stake pages

Screen	Description
	<p>The General page</p> <p>Stake out settings for the point to stake out, for example, point ID or reflector height.</p>
	<p>The Stake page</p> <p>Displays the differences between the measured points and stake out points (delta values). If these values are zero, the measured point coincides with the stake out point.</p>
	<p>The Info page</p> <p>A user definable page displaying values relevant to the measured point.</p>
	<p>The Plot page</p> <p>A graphical representation of the current design in relation to the measured point.</p>

The Check pages

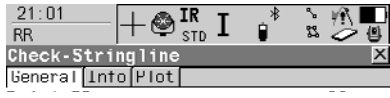
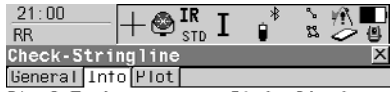
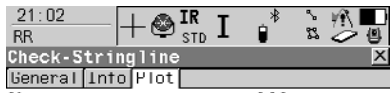

Screen	Description
	The General page Stake out settings for the point to stake out, for example, point ID or reflector height.
	The Info page A user definable page displaying values relevant to the measured point.
	The Plot page A graphical representation of the current design in relation to the measured point.



5.2

The General Page

The General page

Road Stake	Description
<pre> Stake-Stringline ┌General└Stake┌Infn└Plnt Point ID : 001 Reflector Ht : 1.557 m Def Chainage : 200.000 m Ch Increment : 15.000 m Stake Offset : 1.000 m Stake Ht Diff: 0.000 m ALL DIST REC CH+ <PAGE PAGE> </pre>	<p>This page defines the point to be staked. Refer to "Introduction" for details of the main keys.</p> <p>CH+ (F4) To increase Def Chainage by the Ch Increment.</p> <p>SHIFT CONF (F2) To access configuration settings. Refer to "6 Configuring".</p> <p>SHIFT POSIT (F4) To enable automatic instrument positioning. Refer to "6.2.2 The Posit Page (for TPS only)".</p> <p>SHIFT EXTRA (F5) To access the Extras Menu. Refer to "10 Working with the Extras Menu".</p>
<pre> Road Check ┌General└Infn└Plnt Point ID : 001 Reflector Ht : 1.557 m Check Offset : 1.000 m Check Ht Diff: 0.000 m ALL DIST REC <PAGE PAGE> </pre>	<p>This page defines the point to be checked. Refer to "Introduction" for details of the main keys.</p> <p>SHIFT CONF (F2) To access configuration settings. Refer to "6 Configuring".</p> <p>SHIFT EXTRA (F5) To access the Extras Menu. Refer to "10 Working with the Extras Menu".</p>

Field	Description of Field
 The following fields are always shown in all Stake and Check methods.	
Point ID	User input. Name of the next point to be stored. The Point ID will be incremented/decremented whenever a point gets stored with ALL (F1) or REC (F3). Refer to the "TPS1200 Technical Reference Manual" for information on defining the point increment and point ID.
Antenna Ht	<input type="text" value="GPS"/> User input. Height of the antenna.
Reflector Ht	<input type="text" value="TPS"/> User input. Height of the reflector.
 The following fields are always shown in all Stake methods.	
Def Chainage	User input. Nominal chainage of the point to be staked out. If staking out random chainages and no nominal chainage is defined, for example Def Chainage=--- --, no value for Δ Chainage will be displayed on the Stake page. All values will be displayed relative to the current chainage.
Ch Increment	User input. Chainage increment. Value by which the nominal chainage Def Chainage increases/decreases when pressing CH+ (F4). When working with random chainages, for example Def Chainage=-----, this line is disabled.

Field	Description of Field
 The following fields may be shown in the Stake methods.	
Stake Offset	User input. Horizontal offset from the reference stringline (as defined by the chosen method) of the point to stake.
Stake Ht Diff	User input. Vertical offset from the reference stringline or surface (as defined by the chosen method) of the point to stake.
 The following fields may be shown in the Check methods.	
Check Offset	User input. Horizontal offset for stringlines defined by manual offset. Refer to "11.6.2 Stake Offset / Height Difference Working Example" for more information on stake offsets.
Check Ht Diff	User input. Vertical offset for stringlines defined by manual height difference. Refer to "11.6.2 Stake Offset / Height Difference Working Example" for more information on stake height differences.

5.3

The Stake Page

The Stake page (only applicable to stake surveys)

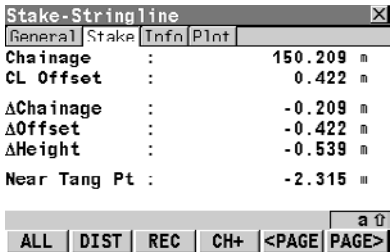
Road Stake	Description																												
 <p>Stake-String line</p> <table border="1"><thead><tr><th>General</th><th>Stake</th><th>Info</th><th>Print</th></tr></thead><tbody><tr><td>Chainage</td><td>:</td><td>150.209</td><td>m</td></tr><tr><td>CL Offset</td><td>:</td><td>0.422</td><td>m</td></tr><tr><td>ΔChainage</td><td>:</td><td>-0.209</td><td>m</td></tr><tr><td>ΔOffset</td><td>:</td><td>-0.422</td><td>m</td></tr><tr><td>ΔHeight</td><td>:</td><td>-0.539</td><td>m</td></tr><tr><td>Near Tang Pt</td><td>:</td><td>-2.315</td><td>m</td></tr></tbody></table> <p>ALL DIST REC CH+ <PAGE PAGE></p>	General	Stake	Info	Print	Chainage	:	150.209	m	CL Offset	:	0.422	m	ΔChainage	:	-0.209	m	ΔOffset	:	-0.422	m	ΔHeight	:	-0.539	m	Near Tang Pt	:	-2.315	m	<p>The values on this page guide you to the position to stake out. All stake out methods share a common Stake page. However the values shown differ, being related to different elements for each stake out method. Variations to the following definitions are indicated in the relevant chapters for each stake out method.</p> <p>Depending on the Orientation and Guidance, as selected in RR Road Configuration, the appearance of this page may vary.</p> <p>Refer to "Introduction" for details of the main keys.</p> <p>CH+ (F4) To increase Def Chainage by the Ch Increment.</p> <p>SHIFT CONF (F2) To access configuration settings. Refer to "6 Configuring".</p> <p>SHIFT POSIT (F4) To enable automatic instrument positioning. Refer to "6.2.2 The Posit Page (for TPS only)".</p> <p>SHIFT EXTRA (F5) To access the Extras Menu. Refer to "10 Working with the Extras Menu".</p>
General	Stake	Info	Print																										
Chainage	:	150.209	m																										
CL Offset	:	0.422	m																										
ΔChainage	:	-0.209	m																										
ΔOffset	:	-0.422	m																										
ΔHeight	:	-0.539	m																										
Near Tang Pt	:	-2.315	m																										

Field	Description of Field
Chainage or Ch	Output. The current chainage. This field is independent of the chosen Orientation and Guidance in RR Road Configuration.
CL Offset or CL O	Output. Perpendicular horizontal offset from the centre line. This field is independent of the chosen Orientation and Guidance in RR Road Configuration.
ΔChainage or ΔCh	Output. Difference between the defined chainage Def Chainage on the General page and the current chainage Chainage of the Stake page. If no defined chainage exists, e.g. if staking out random chainages or checking, this field shows ΔChainage:---- .
ΔOffset or ΔOff	Output. Horizontal offset between the defined position and the current position. The Stake Offset defined on the General page is taken into account.
ΔHeight or ΔHt	Output. Vertical offset between the defined position and the current position. The Stake Ht Diff defined on the General page is taken into account.
Near Tang Pt or NrTP	Output. Chainage difference between the measured point and the nearest tangent point (start/end point of a road segment) of the design. This field is independent of the chosen Orientation and Guidance in the RR Road Configuration.

Field

Description of Field

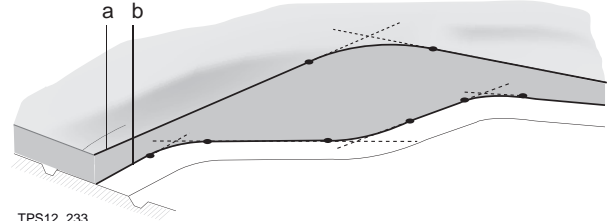

TPS12_233

- a) Vertical alignment
 - a) Horizontal alignment
- Only tangent points (start/end point of a road segment) are detected.

5.4

The Info Page

Description

- A user defineable Info page exists for each of the stake methods and check methods.
 - Refer to "6.4 Road Stake Out Info Page and Road Check Info Page" for information on all available items for the Info page and how to select them.
-

5.5

The Plot Page

The Plot page

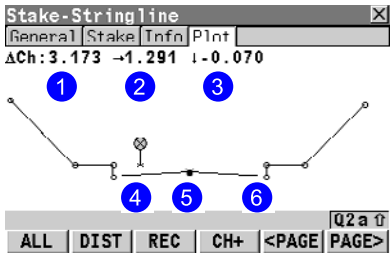
Road Stake	Description
	<p>The Plot page for Road Stake shows information about the measured point relative to the design (as defined by the selected layer and stringline, and the values entered on the General page).</p> <p>The following information is shown:</p> <ol style="list-style-type: none">1. Chainage difference between the measured point and the defined chainage. When working with random chainages (that is, when no defined chainage has been entered on the General page), ΔCh changes to Ch (the current chainage as shown on the Stake page).2. Horiz. distance (left/right arrow) to the design.3. Vert. distance (up/down arrow) to the design.4. The measured point.5. The element to stake is shown in bold. The position to stake is marked with a cross.6. The plot can be shown as a cross plot, plan view or profile view (as defined by the Plot Type setting in RR Road Configuration, Info&Plt page).

Road Stake	Description
	<p>The information at the top of the plot corresponds with the information on the Stake page, only when Orientation=To Alignment is set in RR Road Configuration, General page.</p>

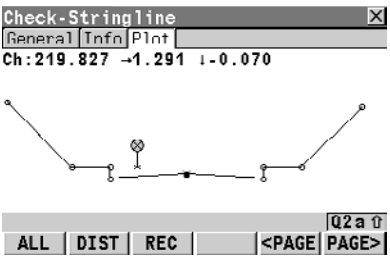
Road Check	Description
	<p>The Plot page for Road Check is similar to Road Stake. The only difference is that the current chainage is always shown, as shown on the Info page.</p>

Refer to "11.4" and "11.5" for details on plots with shifts and stake offsets/height differences.

The cross plot view

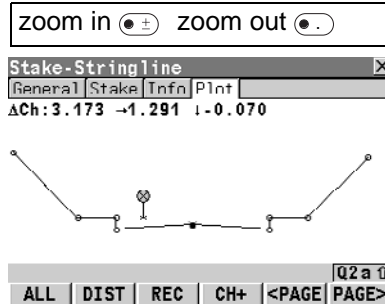

Refer to "Introduction" for details of the main keys.

CH+ (F4) (only available for Road Stake)

To increase Def Chainage by the Ch Increment.

SHIFT CONF (F2)

To access configuration settings.

Refer to "6 Configuring".

SHIFT FIT (F3)

To fit all data into the screen area.

SHIFT CENTR (F4)

To centre the plot at the selected element.

SHIFT EXTRA (F5)

To access the Extras Menu.

Refer to "10 Working with the Extras Menu".

The profile view

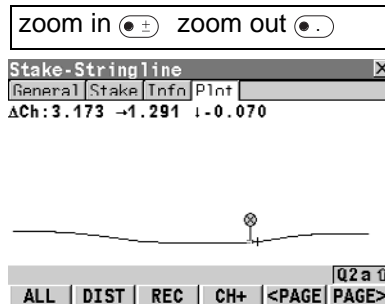

Refer to "Introduction" for details of the main keys.

CH+ (F4) (only available for Road Stake)

To increase Def Chainage by the Ch Increment.

SHIFT CONF (F2)

To access configuration settings.

Refer to "6 Configuring".

SHIFT FIT (F3)

To fit all data into the screen area.

SHIFT CENTR (F4)

To centre the plot at the selected element.

The plan view

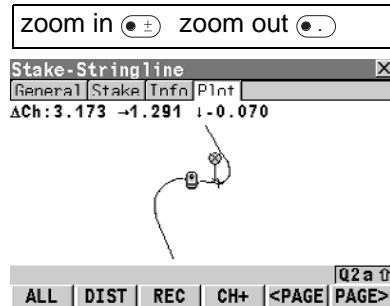

SHIFT EXTRA (F5)

To access the Extras Menu.

Refer to "10 Working with the Extras Menu".

Refer to "Introduction" for details of the main keys.

CH+ (F4) (only available for Road Stake)

To increase Def Chainage by the Ch Increment.

SHIFT CONF (F2)

To access configuration settings.

Refer to "6 Configuring".

SHIFT FIT (F3)

To fit all data into the screen area.

SHIFT CENTR (F4)

To centre the plot at the selected element.

SHIFT EXTRA (F5)

To access the Extras Menu.

Refer to "10 Working with the Extras Menu".

5.6

Measuring Points by Chainage and Offset

Graphical overview

Road Stake

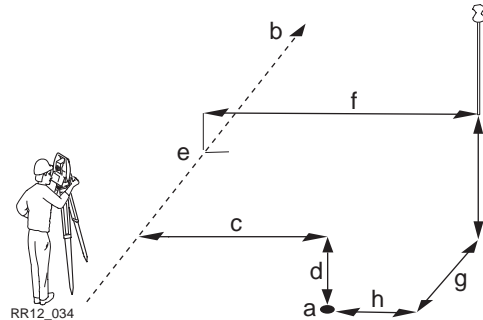

- a) Position to stake out, defined by chainage, stake offset and, optionally, stake height difference
- b) Centre line/stringline the position is defined relative to
- c) **Stake Offset**
- d) **Stake Ht Diff**
- e) **Chainage**
- f) **CL Offset**
- g) **Δ Chainage**
- h) **Δ Offset**
- i) **Δ Height**

Road Check

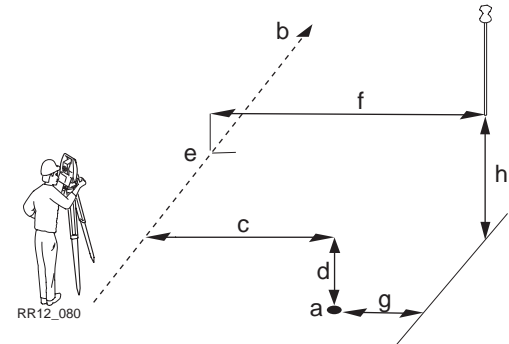

- a) Position to check, defined by check offset and, optionally, check height difference
- b) Centre line/stringline the position is defined relative to
- c) **Check Offset**
- d) **Check Ht Diff**
- e) **Chainage**
- f) **CL Offset**
- g) **Strgl Offset**
- h) **Strgl Ht Diff**

Description

- When staking points, these are points that have been defined manually by chainage and offset relative to an existing 2D or 3D centre line or stringline.

-
- When checking points, these are points that have been defined manually by chainage and offset relative to an existing 2D or 3D centre line or stringline.

Required elements

-
- For **Method: 2D** a horizontal centre line is required.
 - For **Method: 3D** a 3D centre line is required.
-

5.7

Measuring Stringlines Relative to a Centre Line

Graphical overview

Road Stake

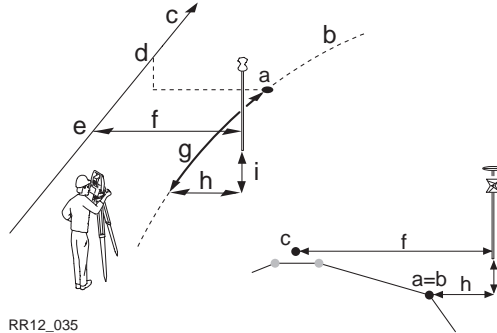

RR12_035

- a) Position to stake out
- b) Stringline to stake out
- c) Centre line
- d) **Def Chainage**
- e) **Chainage**
- f) **CL Offset**
- g) **Δ Chainage**
- h) **Δ Offset**
- i) **Δ Height**

Road Check

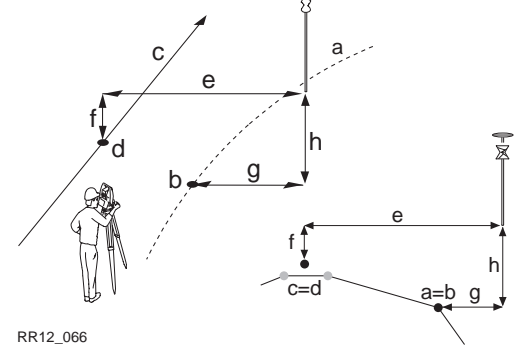

RR12_066

- a) Stringline to check
- b) Projected point on stringline
- c) Centre line
- d) **Chainage**
- e) **CL Offset**
- f) **CL Ht Diff**
- g) **Strgl Offset**
- h) **Strgl Ht Diff**

Description

- Stringlines define various elements, including:
 - Centre line of the design.
 - Change in slope ratio, for example, the edge of a carriage way.
 - Gutter, cable, pipeline or any other type of alignment element.

-
- Refer to "11.3 Basic Elements for Road Stake and Check Measurements" for information on the usage of stringlines.

Required elements

-
- For **Method: 2D** at least a 2D stringline and a 2D centre line are required.
 - For **Method: 3D** a 3D stringline and a 3D centre line are required.
-

5.8

Measuring Individual Stringlines without Centre Lines

Graphical overview

Road Stake

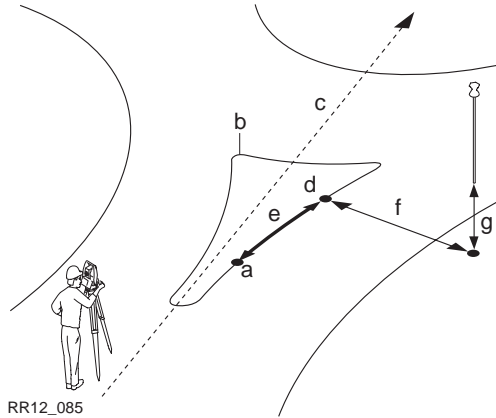

RR12_085

Stake Out of Roundabout

- Position to stake out
- Stringline to stake out
- Centre line of the layer- is not used for the individual stringline
- Chainage**
- Δ Chainage**
- Δ Offset**
- Δ Height**

Road Check

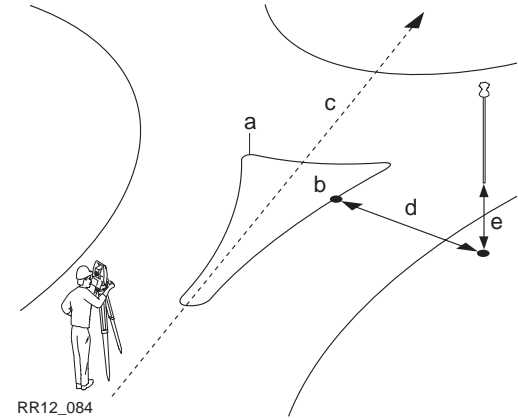

RR12_084

Checking a Roundabout

- Stringline to check
- Chainage**
- Centreline of the layer- is not used for the individual stringline
- Strgl Offset**
- Strgl Ht Diff**

Description

Different to stringlines, where the stake/check is always relative to the centre line defined for the layer, individual stringlines have no longer a relation to an overall centre line. Individual

stringlines are used to check roundabouts, parking bays, subdivision works and any other type of lines. The different stringlines to stake/check can be stored within one layer, which does not require a defined centre line. This is different to the stake/check of any other type which always require a centre line.

Required elements

A 2D or 3D design of the line to stake/check is required.

Indefinite triangle

Description

In almost all situations, a measured position is shown relative to the individual stringline by the stringline chainage and a square offset to the stringline. However, situations may arise where a road design has extreme changes in the deflection angle of tangent points. In these cases it is not always possible to show a measured position by the nominal chainage and offset. An indefinite triangle is a region in which these situations arise. Points measured within an indefinite triangle are shown relative to the tangent point.

Graphic

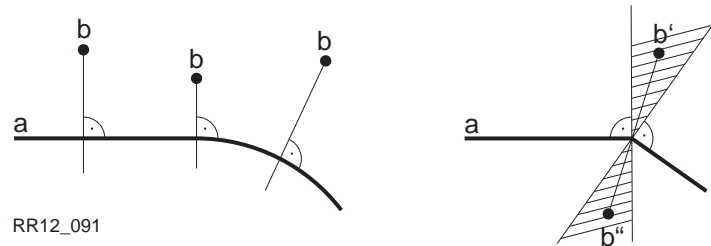

RR12_091

Road Design A

- a) Individual stringline
- b) Measured position (displayed relative to the stringline by chainage and square offset)

Road Design B

- a) Individual stringline with extreme changes in the deflection angle of tangent points
This position **cannot** be shown in the usual manner and is displayed relative to the tangent point
- b) Measured position within indefinite triangle
This position **can** be shown in the usual manner and is displayed by chainage and square offset

Screen

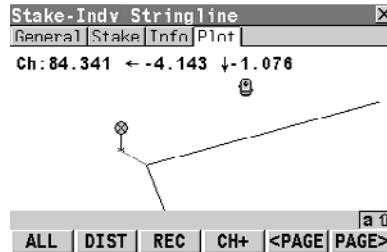

Points measured within an indefinite triangle are always shown relative to the tangent point.

5.9 Measuring Cross Slopes

Graphical overview

Road Stake

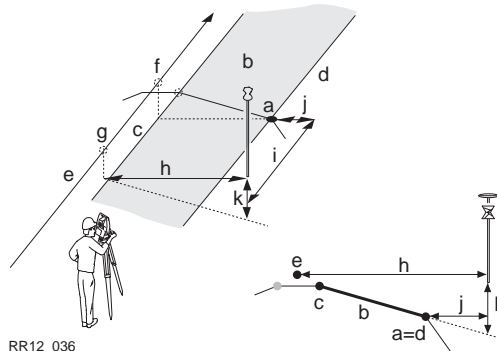

RR12_036

- a) Position to stake out
- b) X-slope to stake out
- c) Left stringline
- d) Right stringline
- e) Centre line
- f) **Def Chainage**
- g) **Chainage**
- h) **CL Offset**
- i) **ΔChainage**
- j) **ΔOffset**
- k) **ΔHeight**

Road Check

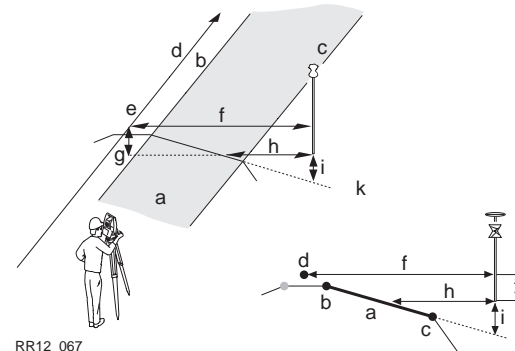

RR12_067

- a) X-slope to check
- b) Left stringline
- c) Right stringline
- d) Centre line
- e) **Chainage**
- f) **CL Offset**
- g) **CL Ht Diff**
- h) **X-Slp Offset**
- i) **X-Slp Ht Diff**

Description

- Surfaces such as the final carriage way, are often staked/checked using X-slopes. A X-slope consists of a combination of two stringlines. Refer to "11.3 Basic Elements for Road Stake and Check Measurements" for information on the usage of X-slopes.

Required elements

A 3D design of the road is required.

5.10

Measuring Manual Slopes and Design Slopes

5.10.1

Overview

Graphical overview

Road Stake

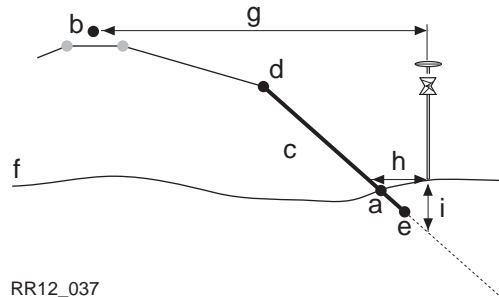

RR12_037

- a) Catch point
- b) Centre line
- c) Slope to stake out
- d) Hinge point = left stringline
- e) Second / right stringline
- f) Natural surface
- g) **CL Offset**
- h) **ΔOffset**
- i) **ΔHeight**

Road Check

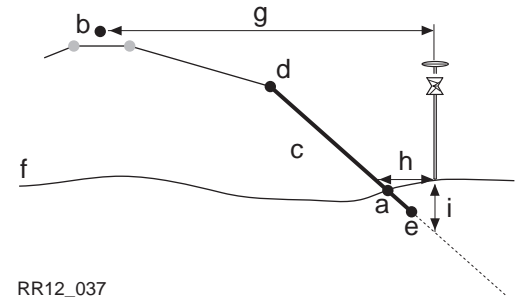

RR12_037

- a) Catch point
- b) Centre line
- c) Slope to check
- d) Hinge point
- e) Second stringline of the slope
- f) Natural surface
- g) **CL Offset**
- h) **Slope Offset**
- i) **Slope Ht Diff**

Description

- Surfaces, such as the end slopes of a cut or fill, are staked/checked using slope methods.
- Slopes are defined by two stringlines. Refer to "11.3 Basic Elements for Road Stake and Check Measurements" for information on the usage of slopes.

Description of manual slopes

Description of design slopes

- When staking slopes, the point of interest is the intersection of the defined slope with the natural surface (= catch point). Refer to "11.7 Methods for Slope Staking" for information on the slope staking methods supported by RoadRunner.
 - When checking slopes, the slope check is independent of the Slope Method chosen in RoadRunner Road Configuration.
-

- For this method the slope is defined manually relative to an existing centre line.
-

- For this method a 3D representation of the slope is required.
-

5.10.2

Defining the Slope Type - Using no Slope

Configuring the slope

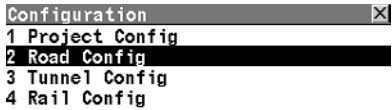
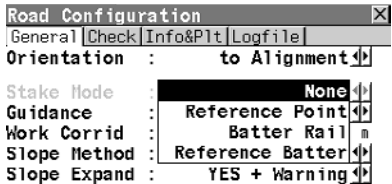
Screen	Step	Description
	1	Select Road Config. Press CONT (F1) to continue to the next screen.
	2	When no slope type is required: set Slope Method=None.

Entering the values
(Standard Mode)

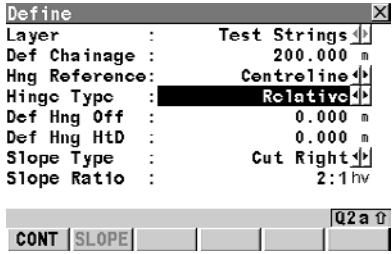
Screen	Description
	After setting Slope Method=None, the SLOPE (F2) key in the Define screen is disabled and no slope values can be entered.

5.10.3

Defining the Slope Type - Using a Reference Point

Configuring the slope

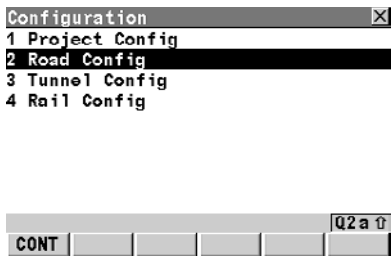
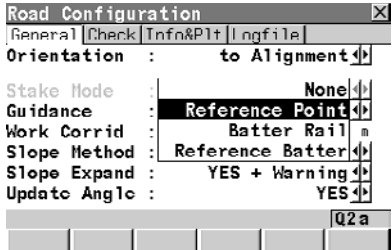
Screen	Step	Description
	1	Select Road Config. Press CONT (F1) to continue to the next screen.
	2	When a reference point is required: set Slope Method=Reference Point.

Entering the values
(Standard Mode)

Screen	Step	Description
<div data-bbox="427 176 817 431"> <p>Define X</p> <p>Layer : Test Strings</p> <p>Def Chainage : 200.000 m</p> <p>Hng Reference: Controline</p> <p>Hngc Type : Relative</p> <p>Def Hng Off : 0.000 m</p> <p>Def Hng HtD : 0.000 m</p> <p>Slope Type : Cut Right</p> <p>Slope Ratio : 2:1 hv</p> <hr/> <p>CONT SLOPE Q2a ↑</p> </div>	1	<p>After setting Slope Method=Reference Point in the configuration screen, the SLOPE (F2) key in the Define screen is enabled and slope values for the reference point can be entered.</p> <p>Press SLOPE (F2) to continue to the next screen.</p>
<div data-bbox="427 451 817 700"> <p>Selection Wizard-Slope X</p> <p>Ref Offset : 0.000 m</p> <div data-bbox="486 543 742 632" style="text-align:center;"> </div> <hr/> <p>CONT Q2a ↑</p> </div>	2	<p>It is now possible to stake out a reference point with a defined offset from the catch point. Enter the appropriate values.</p>

Entering the values (Advanced Mode)

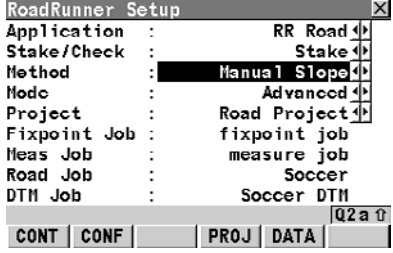
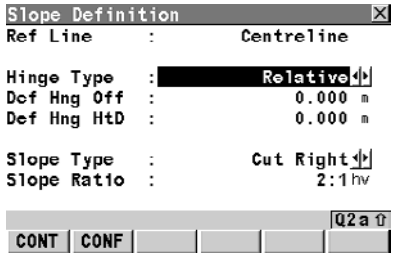
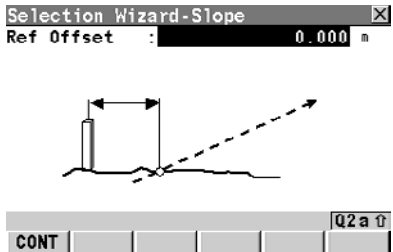
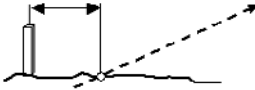
Screen	Step	Description
 <p>RoadRunner Setup</p> <p>Application : RR Road</p> <p>Stake/Check : Stake</p> <p>Method : Manual Slope</p> <p>Mode : Advanced</p> <p>Project : Road Project</p> <p>Fixpoint Job : fixpoint job</p> <p>Meas Job : measure job</p> <p>Road Job : Soccer</p> <p>DTH Job : Soccer DTH</p> <p>CONT CONF PROJ DATA Q2 a ↑</p>	1	<p>After setting Slope Method=Reference Point in the configuration screen, a task is created or selected and then the instrument is positioned and oriented.</p> <p>Press CONT (F1) to go to Task Management.</p>
 <p>Slope Definition</p> <p>Ref Line : Centreline</p> <p>Hinge Type : Relative</p> <p>Def Hng Off : 0.000 m</p> <p>Def Hng HtD : 0.000 m</p> <p>Slope Type : Cut Right</p> <p>Slope Ratio : 2:1hv</p> <p>CONT CONF Q2 a ↑</p>	2	<p>Enter appropriate values for the slope definition.</p> <p>Refer to "10.8 Extras for Slope" for details of the fields in this screen.</p> <p>Refer to "11.7.3 Slope Staking Using a Reference Point" for further details on using a reference point.</p> <p>Press CONT (F1) to continue to the next screen.</p>
 <p>Selection Wizard-Slope</p> <p>Ref Offset : 0.000 m</p>  <p>CONT Q2 a ↑</p>	3	<p>It is now possible to stake out a reference point with a defined offset from the catch point. Enter the appropriate values.</p> <p>Refer to "4.3.6 Selection Wizard - Slope Screen" for further details on using the Task selection wizard.</p>

Workflow

- Refer to "11.7.3 Slope Staking Using a Reference Point" for more information on the reference point method.
- The first position to stake out is the catch point.

Step	Description
1.	Stake out the position of the catch point by using ΔOffset and/or ΔHeight . When ΔOffset and ΔHeight are equal to zero, the catch point has been located.
2.	SHIFT EXTRA (F5) to access RR Extras- Slope .
3.	Select Place Reference Point to access the stake out screen for the reference peg RR Stake - Refpoint . The measured position from step 1 is used as the catch point for the stake out of the reference point.
4.	Stake out the reference point using ΔOffset . When ΔOffset is equal to zero the reference peg position has been found. ΔHeight shows the height difference relative to the catch point. Note that all values shown on the Info page are relative to the original slope.
5.	ESC to return to RR Stake Slope . Stake out the next catch point from this screen.

5.10.4

Defining the Slope Type - Using a Batter Rail

Configuring the slope

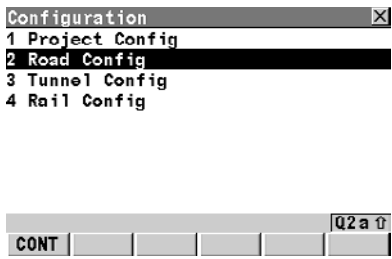
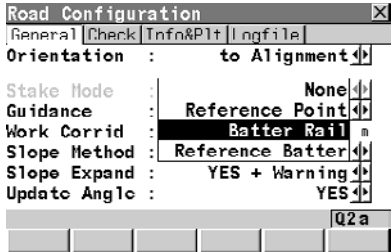
Screen	Step	Description
 <p>The screenshot shows a 'Configuration' window with a list of options: 1 Project Config, 2 Road Config (highlighted), 3 Tunnel Config, and 4 Rail Config. At the bottom, there is a 'CONT' button and a 'Q2a' prompt.</p>	1	<p>Select Road Config to continue to the Road Configuration screen.</p> <p>Press CONT (F1) to continue to the next screen.</p>
 <p>The screenshot shows the 'Road Configuration' dialog box. The 'Slope Method' is set to 'Batter Rail'. Other options include Stake Mode (None), Guidance (Reference Point), Work Corrid (Batter Rail), Slope Expand (YES + Warning), and Update Angle (YES). At the bottom, there is a 'Q2a' prompt.</p>	2	<p>When a batter rail is required: set Slope Method=Batter Rail.</p>

Entering the values
(Standard Mode)

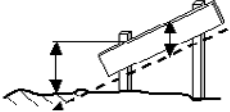
Screen	Step	Description
<div data-bbox="427 176 817 431"> <p>Define [X]</p> <p>Layer : Test Strings [v]</p> <p>Def Chainage : 200.000 m</p> <p>Hng Reference: Controline [v]</p> <p>Hngc Type : Relative [v]</p> <p>Def Hng Off : 0.000 m</p> <p>Def Hng HtD : 0.000 m</p> <p>Slope Type : Cut Right [v]</p> <p>Slope Ratio : 2:1 hv</p> <p>[Q2a ↑]</p> <p>CONT SLOPE [] [] [] []</p> </div>	1	<p>After setting Slope Method=Batter Rail in the configuration screen, the SLOPE (F2) key in the Define screen is enabled and slope values for the batter rail can be entered.</p> <p>Press SLOPE (F2) to continue to the next screen.</p>
<div data-bbox="427 451 817 700"> <p>Selection Wizard-Slope [X]</p> <p>Batter Type : Cut [v]</p> <p>Rail ov Batt : 0.000 m</p> <p>Rail ov Grnd : 0.000 m</p>  <p>[Q2a ↑]</p> <p>CONT [] [] [] [] []</p> </div>	2	<p>It is now possible to stake out a batter rail with a defined peg height. Enter the appropriate values.</p>

Entering the values (Advanced Mode)

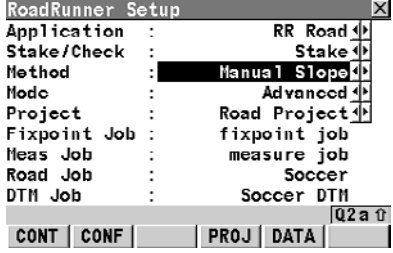
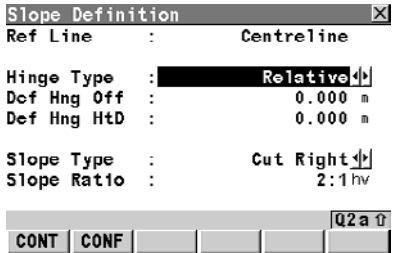
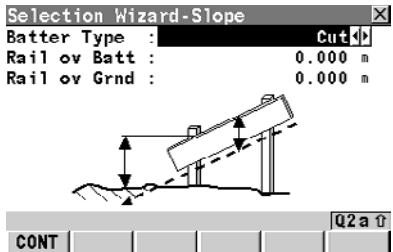
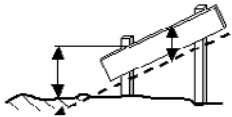
Screen	Step	Description
 <p>RoadRunner Setup</p> <p>Application : RR Road</p> <p>Stake/Check : Stake</p> <p>Method : Manual Slope</p> <p>Mode : Advanced</p> <p>Project : Road Project</p> <p>Fixpoint Job : fixpoint job</p> <p>Meas Job : measure job</p> <p>Road Job : Soccer</p> <p>DTH Job : Soccer DTH</p> <p>Q2 a ↑</p> <p>CONT CONF PROJ DATA</p>	1	<p>After setting Slope Method=Batter Rail in the configuration screen, a task is created or selected and then the instrument is positioned and oriented.</p> <p>Press CONT (F1) to continue to the next screen.</p>
 <p>Slope Definition</p> <p>Ref Line : Centreline</p> <p>Hinge Type : Relative</p> <p>Def Hng Off : 0.000 m</p> <p>Def Hng HtD : 0.000 m</p> <p>Slope Type : Cut Right</p> <p>Slope Ratio : 2:1 hv</p> <p>Q2 a ↑</p> <p>CONT CONF</p>	2	<p>Enter appropriate values for the slope definition.</p> <p>Refer to "10.8 Extras for Slope" for details of the fields in this screen.</p> <p>Refer to "11.7.4 Slope Staking With Batter Rails" for further details on using a batter rail.</p> <p>Press CONT (F1) to continue to the next screen.</p>
 <p>Selection Wizard-Slope</p> <p>Batter Type : Cut</p> <p>Rail ov Batt : 0.000 m</p> <p>Rail ov Grnd : 0.000 m</p>  <p>Q2 a ↑</p> <p>CONT</p>	3	<p>It is now possible to stake out a batter rail with a defined peg height. Enter the appropriate values.</p> <p>Refer to "4.3.6 Selection Wizard - Slope Screen" for further details on using the Task selection wizard.</p>

Workflow

- Refer to "11.7.4 Slope Staking With Batter Rails" for more information on the batter rail method.
- The first peg to stake out is always the peg closest to the hinge point.

Step	Description
1.	Stake out the position of the first peg of the batter by using ΔOffset . The height of the rail over ground Rail over Grd is taken into account for ΔOffset . This means that when ΔOffset is equal to zero the first peg is in the correct position.
2.	Place the pole on top of the first peg. The value for ΔHeight indicates how far below the top of the peg the batter has to be placed.
3.	Stake out the second peg of the batter rail by using ΔChainage and place the peg.
4.	Place the pole on the position of the batter rail to be used as a reference for the slope values to mark on the batter rail. ΔHeight should read now zero. Note that all values shown under the Info page are relative to the original slope.

5.10.5

Defining the Slope Type - Using a Reference Batter

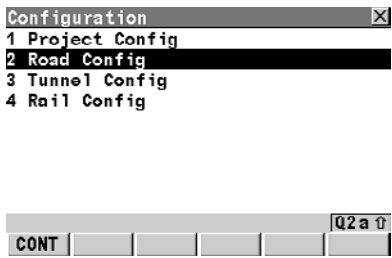
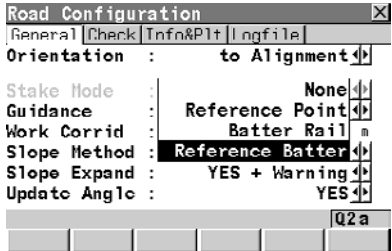

Configuring the slope

Screen	Step	Description
 <p>The screenshot shows a 'Configuration' window with a menu containing four options: '1 Project Config', '2 Road Config', '3 Tunnel Config', and '4 Rail Config'. The '2 Road Config' option is highlighted. Below the menu is a 'CONT' button and a 'Q2a' prompt.</p>	1	<p>Select Road Config to continue to the Road Configuration screen.</p> <p>Press CONT (F1) to continue to the next screen.</p>
 <p>The screenshot shows a 'Road Configuration' window with several settings. The 'Slope Method' is set to 'Reference Batter'. Other settings include 'Stake Mode' (None), 'Guidance' (Reference Point), 'Work Corrid' (Batter Rail), and 'Slope Expand' (YES + Warning). There is also an 'Update Angle' setting set to YES.</p>	2	<p>When a reference batter is required: set Slope Method=Reference Batter.</p>

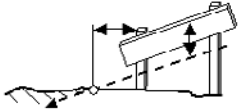
Entering the values
(Standard Mode)

Screen	Step	Description
<div data-bbox="427 176 817 431"> <p>Define [X]</p> <p>Layer : Test Strings</p> <p>Def Chainage : 200.000 m</p> <p>Hng Reference: Centreline</p> <p>Hngc Typec : Relative</p> <p>Def Hng Off : 0.000 m</p> <p>Def Hng HtD : 0.000 m</p> <p>Slope Type : Cut Right</p> <p>Slope Ratio : 2:1 hv</p> <p>Q2a ↑</p> <p>CONT SLOPE </p> </div>	1	<p>After setting Slope Method=Batter Rail in the configuration screen, the SLOPE (F2) key in the Define screen is enabled and slope values for the batter rail can be entered.</p> <p>Press SLOPE (F2) to continue to the next screen.</p>
<div data-bbox="427 451 817 700"> <p>Selection Wizard-Slope [X]</p> <p>Ref Offset : 0.000 m</p> <p>Traveller Ht : 0.000 m</p>  <p>Q2a ↑</p> <p>CONT </p> </div>	2	<p>It is now possible to stake out a batter rail with a defined offset from the catch point. Enter the appropriate values.</p>

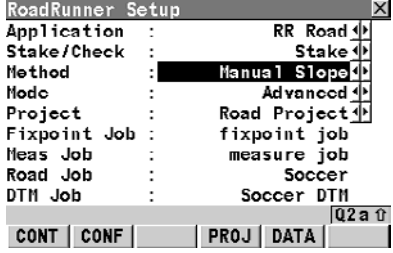
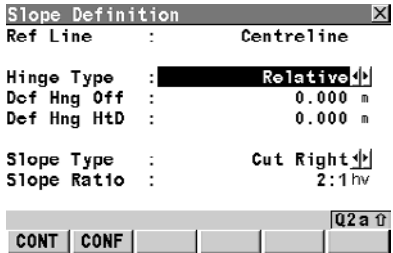
Entering the values (Advanced Mode)

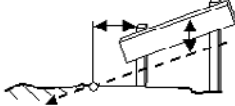
Screen	Step	Description
 <p>RoadRunner Setup</p> <p>Application : RR Road</p> <p>Stake/Check : Stake</p> <p>Method : Manual Slope</p> <p>Mode : Advanced</p> <p>Project : Road Project</p> <p>Fixpoint Job : fixpoint job</p> <p>Meas Job : measure job</p> <p>Road Job : Soccer</p> <p>DTH Job : Soccer DTH</p> <p>CONT CONF PROJ DATA Q2 a ↑</p>	1	<p>After setting Slope Method=Batter Rail in the configuration screen, a task is created or selected and then the instrument is positioned and oriented.</p> <p>Press CONT (F1) to continue to the next screen.</p>
 <p>Slope Definition</p> <p>Ref Line : Centreline</p> <p>Hinge Type : Relative</p> <p>Def Hng Off : 0.000 m</p> <p>Def Hng HtD : 0.000 m</p> <p>Slope Type : Cut Right</p> <p>Slope Ratio : 2:1 hv</p> <p>CONT CONF Q2 a ↑</p>	2	<p>Enter appropriate values for the slope definition.</p> <p>Refer to "10.8 Extras for Slope" for details of the fields in this screen.</p> <p>Refer to "11.7.5 Staking Batter Rails Using a Reference Point" for further details on using a batter rail.</p> <p>Press CONT (F1) to continue to the next screen.</p>
 <p>Selection Wizard-Slope</p> <p>Ref Offset : 0.000 m</p> <p>Traveller Ht : 0.000 m</p>  <p>CONT Q2 a ↑</p>	3	<p>It is now possible to stake out a batter rail with a defined offset from the catch point. Enter the appropriate values.</p> <p>Refer to "4.3.6 Selection Wizard - Slope Screen" for further details on using the Task selection wizard.</p>

Workflow

- Refer to "11.7.5 Staking Batter Rails Using a Reference Point" for more information on the reference batter rail method.
- The first position to stake out is the catch point.

Step	Description
1.	Stake out the position of the catch point by using ΔOffset and/or ΔHeight . When ΔOffset and ΔHeight are equal to zero, the catch point has been located.
2.	SHIFT EXTRA (F5) to access RR Extras- Slope . The measured position is used as the catch point for the stake out of the reference point.
3.	Select Place Reference Point to access the stake out screen for the reference peg RR Stake - Refpoint .
4.	Stake out the reference point using ΔOffset . When ΔOffset is equal to zero the reference peg position has been found.
5.	Place the pole on top of the reference peg. The value for ΔHeight indicates how far below the top of the peg the batter has to be placed.
6.	Place the pole on the position of the batter rail to be used as a reference for the slope values to mark on the batter rail. ΔHeight should now read zero. Note that all values shown under the Info page are relative to the original slope.
7.	ESC to return to RR Stake Slope . Stake out the next catch point from this screen.

5.11

Measuring Road Crowns

Graphical overview

Road Stake

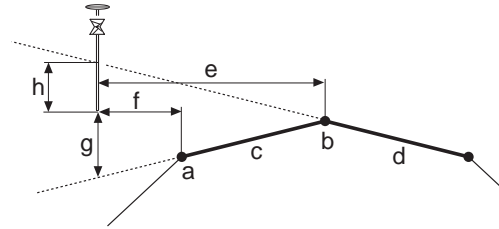

RR12_040

- a) Position to stake out, in this case the left stringline of the crown
- b) Middle stringline of the crown, in this case also the centre line
- c) Left X-slope to stake out
- d) Right X-slope to stake out
- e) **CL Offset**
- f) **ΔOffset**
- g) **ΔHt Left**
- h) **ΔHt Right**

Road Check

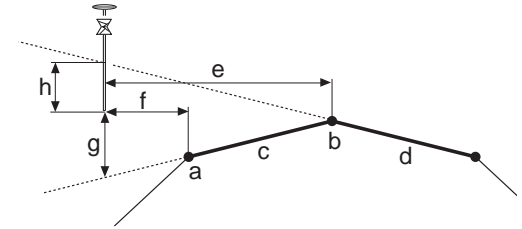

RR12_076

- a) Left stringline of the crown
- b) Middle stringline of the crown, common for both X-slopes
- c) Left X-slope to check
- d) Right X-slope to check
- e) **CL Offset**
- f) **ΔOffset**
- g) **ΔHt Left**
- h) **ΔHt Right**

Description

- When staking road crowns, it allows the stake out of two X-slopes at the same time. If the zig zag mode is selected, RoadRunner automatically switches between the right and left X-slope as the reference for **ΔOffset** depending on whether the measured position is to the left or right of the middle stringline.
- When checking road crowns, it allows the check of two X-slopes at the same time. The information for both X-slopes is shown at the same time.

Required elements

A 3D design of the road is required.

Specific fields

The following fields vary from the description used in "5.2 The General Page":

Field	Option	Description
ΔHt Left, ΔHt Right, or ΔHt L / ΔHt R	Output	Vertical offset to the left/right X-slope defining the road crown.

5.12

Measuring Road Layers

Graphical overview

Road Stake

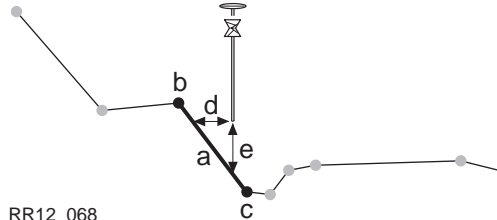

RR12_068

- a) Relevant part of the layer for the current position
- b) Left stringline **Left Name**
- c) Right stringline **Right Name**
- d) **Δ Offset**
- e) **Δ Height**

Road Check

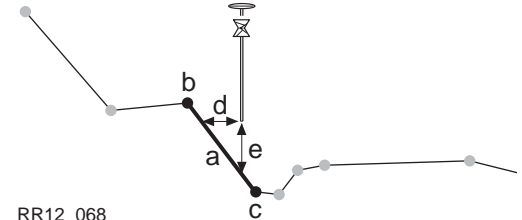

RR12_068

- a) Relevant part of the layer for the current position
- b) Left stringline **Left Name**
- c) Right stringline **Right Name**
- d) **Slope Offset**
- e) **Layer Ht Diff**

Description

- All stringlines are grouped in layers. Such a layer describes a surface of the road. When staking/checking out a layer, RoadRunner automatically detects the stringline left and right of the measured position.

Required elements

A 3D design of the road is required.

5.13

Measuring Digital Terrain Models (DTM)

Graphical overview

Road Stake

Road Check

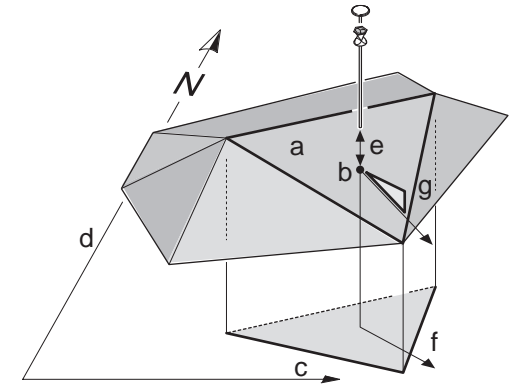

RR12_046

- a) Relevant triangle of the DTM
- b) Projected point on DTM
- c) Easting
- d) Northing
- e) **DTM Ht Diff**
- f) **Flow Directn**
- g) **Flow Ratio**

Description

- A DTM check returns the height difference between the current height and the height the DTM at the measured position.

Required elements

A DTM job is required.

6**Configuring****6.1****Overview of all Configuration Settings****Accessing the screens**

Press CONF (F2) on the RoadRunner Begin screen or RoadRunner Setup screen, or Press SHIFT CONF (F2) on the Define page and on any page of the measurement screen.

Description

The RoadRunner configurations are separated in three different groups:

Type	Description
System configuration	General parameters. For example, angle and distance units.
Project configuration	Project parameters. For example, the display format used for chainages.
Road configuration	Road parameters. For example, the vertical exaggeration of cross section plots.

RR Configuration

The option **Tunnel Config** is only available if the Tunnel program has been loaded (for TPS). The option **Rail Config** is only available if the Rail program of has been loaded.

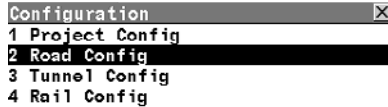

CONT (F1)

To access the highlighted configuration type.

Screen	Description
Project Config	These configuration settings refer to general parameters that apply to all projects (road, tunnel and rail projects). They define the appearance and behaviour common for all parts of the RoadRunner program.
Road Config	These configuration settings refer to parameters that apply only to Road projects.
Tunnel Config	These configuration settings refer to parameters that apply only to Tunnel projects (for TPS).
Rail Config	These configuration settings refer to parameters that apply only to Rail projects. The Rail configuration consists of four pages where parameters relating to the configuration of the program may be modified.

6.2 Configuration Settings for the Project - Project Config

6.2.1 The General Page

Accessing the screens

Select Project Config on the RoadRunner Configuration screen and press CONT (F1).

Description

This defines the appearance/behaviour common to all parts of the RoadRunner program.

The General page

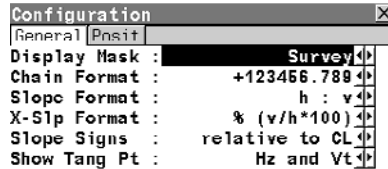

CONT (F1)

To confirm the changes and move to the previous screen.

DMASK (F3)

To configure the selected display mask. Refer to the "Technical Reference Manual".

Field	Option	Description of Field
Display Mask	Chocelist	Selects the user defined display mask shown in the RoadRunner application for all stake out and check methods. All display masks of the active configuration set can be selected.
Chain Format	+123456.789	Selects display format for all chainage information fields. Default chainage display form.

Field	Option	Description of Field
	+123.4+56.789 +123+456.789 +1234+56.789	Separator between tens and hundreds with additional decimal point. Separator between hundreds and thousands. Separators between tens and hundreds.  The distance units Int Ft/Inch (fi) , US Ft/Inch (ft) , Kilometres (km) and US Miles (mi) are only supported by the first chainage format. All other chainage formats are restricted to the base units Metre (m) , Int Ft (fi) and US Ft (ft) .
Slope Format	h:v v:h % (v/h * 100) Elev Angle	Selects the display format for all slope values. Horizontal:Vertical; for example 5:2. Vertical:Horizontal; for example 2:5. For example 40%. Angle, format depends upon system configuration. For example 21.8014 deg, 21°48'05", 24.2238 gon. Refer to the "Technical Reference Manual" for information on available angle formats.
X-Slp Format	h:v, v:h, % (v/h * 100) or Elev Angle	Same as Slope Format . Refer to " Slope Format " above.

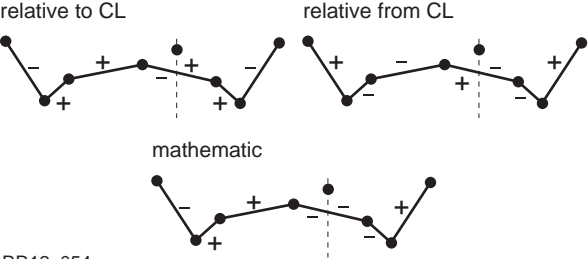
Field	Option	Description of Field
<p>Slope Signs</p>	<p>mathematical relative to CL / relative from CL</p>	<p>Selects sign definition method for slopes and X-slopes.</p> <p>All slopes sign defines from left to right, independent of whether left or right of the centre line. Slope signs defined relative to/from the centre line.</p>  <p>RR12_054</p>
<p>Show Tang Pt</p>	<p>None Hz Vt Hz and Vt</p>	<p>To define if a message box should be shown when a tangent point has been detected within the chainage increment range. This tangent point can be selected for stake-out. Refer to "5.3 The Stake Page" for further details.</p> <p>No tangent points will be indicated.</p> <p>Indicate tangent points of the horiz. alignment only.</p> <p>Indicate tangent points of the vert. alignment only.</p> <p>Indicate all tangent points.</p>

Next step

PAGE (F6) changes to the **Posit** page.

6.2.2 The Posit Page (for TPS only)

Description

This allows the instrument to aim at the position to stake/check. Refer to "6.5 Auto Positioning (TPS only)" for information on the different positioning types. This functionality is only available for motorised instruments.

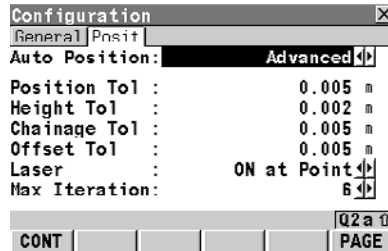

The Posit page



CONT (F1)

To confirm the changes and move to the previous screen.

Field	Option	Description of Field
Auto Position	None	Type of automatic positioning used. No auto position.
	2D (Hz)	Instrument positions horizontally.
	3D (Hz & V)	Instrument positions horizontally and vertically.
	2D + Meas	Instrument positions horizontally and finds the height by iterative distance measurements. Refer to "6.5.2 Auto Position 2D + Measure".
	Advanced	Allows to keep certain values of the current position to remain constant. Refer to "6.5.3 Auto Position Advanced".

Field	Option	Description of Field
		 The following lines will only be enabled for Auto Position: 2D + Meas or Auto Position: Advanced .
Position Tol	From 0.001 to 10	2D distance tolerance to the position to stake out.
Height Tol	From 0.001 to 10	Height tolerance of the position to stake out.
Chainage Tol	From 0.001 to 10	Chainage tolerance of the position to stake out.
Offset Tol	From 0.001 to 10	Offset tolerance of the position to stake out.
Laser	Always off On at Point Always on	Defines when the red laser is turned on during the automatic search of the position. Visible red laser is turned off. Visible red laser is turned on as soon as the point is found. Visible red laser is turned on during the whole search.  The laser can also be permanently turned on by using the instrument settings. Refer to the "Technical Reference Manual" for more information.

Field	Option	Description of Field
Max Iteration	From 2 to 10	Maximum number of iterations for the distance measurement before stopping.

Next step

CONT (F1) to accept the changes and continue.

6.3 Configuration Settings for the Program - Road Config

6.3.1 The General Page

Accessing the screens

Select Road Config on the RoadRunner Configuration screen and press CONT (F1).

The General page

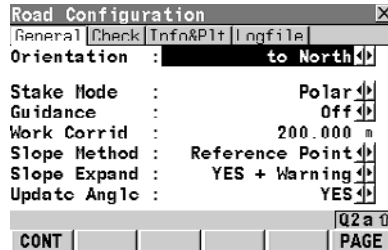

CONT (F1)

To confirm the changes and move to the previous screen.

Field	Description of Field
Orientation	<p>The reference direction used to stake out points. The stake out elements and the graphics displayed are based on this selection.</p> <p>to Alignment The stake out is relative to the alignment. When the stake out mode Stake Mode: Chain&Offset is chosen, this method is selected automatically.</p> <p>to North The north direction of the active coordinate system is used as the reference direction.</p>

Field	Description of Field
	<p data-bbox="836 176 1505 300"> <input type="checkbox"/> to Sun The position of the sun calculated from the almanac in the receiver, irrespective of the local time or position. </p> <p data-bbox="836 316 1505 505"> <input type="checkbox"/> to Last point Use the last recorded point. All point filter settings are ignored. Orientation is truly to the last point stored in the active job. If no last point is available, Orientate: To Station is used for the first point to stake out. </p> <p data-bbox="836 521 1505 583"> <input type="checkbox"/> to Known Point A point from the Meas Job selected. </p> <p data-bbox="836 600 1505 757"> <input type="checkbox"/> to Arrow The direction of the orientation is from the current position to the position to stake out. The graphic displays a moving arrow pointing in the direction of the position to stake out. </p> <p data-bbox="836 773 1505 863"> <input type="checkbox"/> from Station The reference direction is from the station to the current position. </p> <p data-bbox="836 880 1505 969"> <input type="checkbox"/> to Station The reference direction is from the current position to the station. </p>

Field	Description of Field
<p>Stake Mode</p>	<p>Selects the stake out method. Defines the displayed type for the point to stake out.</p> <p>Polar The angular difference from the orientation direction, the horizontal distance and the cut/fill is displayed.</p> <p>Orthogonal The distance forwards/backwards and right/left to the point and the cut/fill is displayed.</p> <p>Chain&Offset Difference in chainage and offset to the stake out position. Only available for Orientate: To Alignment.</p>
<p>Guidance</p>	<p>Off Turns off the bulls-eye view on all stake out screens.</p> <p>Arrows Height differences are shown using arrows up and down. Horizontal differences are represented with arrows left and right.</p> <p>Graphics Bulls-eye view is turned on for all stake out screens.</p>

Field	Description of Field
	Arrows & Graphics Horizontal and height differences are shown using arrows up/down and left/right. The bulls-eye view on all stake out screens is turned on.
Work Corrid	User Input Valid offset range defined by the working corridor left and right of the centre line. Refer to "11.9 Working Corridor" for more information on the working corridor.
Slope Method	None, Reference Point, Batter Rail or Reference Batter Selects the working method used for slope staking. Refer to "11.7 Methods for Slope Staking" for information on the different methods of slope staking.
Slope Expand	To configure the warning handling for slope stake-out. This allows the workflow of slope stake-out to be optimised. Three methods are available. YES + Warning The slope is expanded beyond and above or below the hinge point. A warning is shown as soon as leaving the defined area.

Field	Description of Field
	<p>YES The slope is expanded beyond and above or below the hinge point. No warning is when leaving the defined area.</p> <p>NO The slope is not expanded beyond and above or below the hinge point.</p>
Update Angle	<p><input type="checkbox"/> Yes Angles are updated with telescope movement after a distance was measured.</p> <p><input type="checkbox"/> No Angles and stake out values are updated after a distance measurement. All values are then frozen until the next distance is taken. When Automation: LOCK is selected and the instrument is locked onto a target the angular values do not change.</p>

Next step

PAGE (F6) changes to the **Check** page.

6.3.2

The Check Page

The Check page

Description

Especially when checking points in an as-built control it is useful to enable the Quality Check criteria available under RoadRunner Road Configurations. For every point stored the chosen parameters are checked and if the check limits are exceeded a warning is shown. This guarantees a higher productivity as it is no longer necessary to check the values for every shot taken. When checking layers of a road a too thick layer results in higher costs as more material is used, a too thin layer can lead to problems and might cause serious damage. Therefore RoadRunner enables you to define different check limits for above and below the design.

Graphic

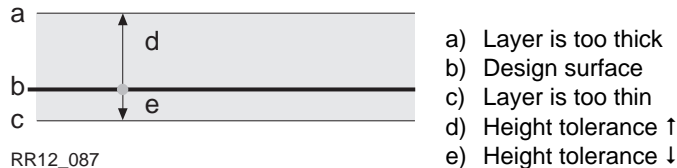

RR12_087

Be aware that height tolerances below the design surface are entered as negative values (for example, the Height Tol ↓ with -10mm from above). By using the signs of the height tolerances it is also possible to cover situations like the one shown below with a valid range between -10 to -50mm below the design surface.

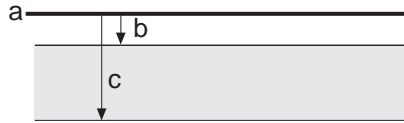

RR12_088

- a) Design surface
- b) Height tolerance ↑
- c) Height tolerance ↓

Like all configurations the settings for Height Tol ↓ and Height Tol ↑ are stored as part of the configuration set.

Screen

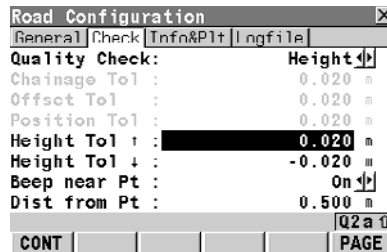

CONT (F1)

To confirm the changes and move to the previous screen.

Field	Option	Description of Field
Quality Check	None	Activates a position check when storing a staked or checked point. When the defined tolerance is exceeded, the stake out/check can be repeated, skipped or stored. No quality check during stake out/check of points.

Field	Option	Description of Field
	Ch&Off&Ht Ch&Off Pos&Ht Position Height	Check for chainage, horizontal offset and height. Check for chainage and horizontal offset. Check for 2D position and height. Check for 2D position. Check for height.  Depending on this selection the lines below are enabled/disabled.
Chainage Tol	From 0.001 to 100	Maximum difference in chainage.
Offset Tol	From 0.001 to 100	Maximum horizontal offset from defined position.
Position Tol	From 0.001 to 100	Maximum radial horizontal distance.
Height Tol ↑	From 0.001 to 100	Maximum height difference.
Height Tol ↓	From 0.001 to 100	Maximum height difference.
Beep near Pt	On or Off	Activates an acoustic warning signal when the horizontal radial distance from the current position to the point to stake out is equal or less than defined in Dist from Pt .

Field	Option	Description of Field
Dist from Pt	User input	Available when Beep near Pt: On is selected. The horizontal radial distance from the current position to the point to stake out within which the acoustic warning signal is active.

Next step

PAGE (F6) changes to the **Info&Plt** page.

6.3.3 The Info&Plot Page

The Info&Plt page

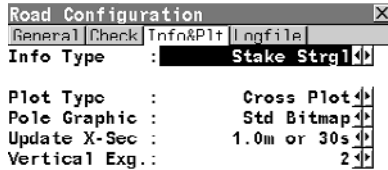



CONT (F1)

To confirm the changes and move to the previous screen.

EDIT (F3)

To edit the highlighted Info Type.

Field	Option	Description of Field
Info Type	Chocelist	List of the different info pages available for stake-out and check. Refer to "6.4 Road Stake Out Info Page and Road Check Info Page" for information on how to define info pages.
Plot Type	Cross Plot	To configure the required plot view. The Plot page in stake out and check shows a cross plot of the design at the current chainage.
	Plan view	The Plot page in stake out and check shows the design from a birds eye view. The plan view includes the current station setup point, the point to stake out and the projected point on the stringline.
	Profile view	The Plot page in stake out and check shows a long-section (height over chainage) of the design.

Field	Option	Description of Field
Pole Graphic	Std Bitmap	The pole indicating the current position in the stake out and check Plot page is shown as a standard bitmap.
	Actual Height	The pole indicating the current position in the stake out and check Plot page is scaled depending on the chosen pole height.
Update X-Sec	0.5m or 10s, 1.0m or 30s or 5.0m or 1min	<p>Update frequency of the cross section view on the Plot page when working in tracking mode.</p> <p> The current position is updated with the selected frequency. Also all values shown for stake out or on the info pages are permanently updated. Only the representation of the cross section is updated after a chainage difference of X m and any X s/min.</p> <p> If not working in tracking mode the cross section view is updated with every measurement.</p> <p> A high update frequency can result in a lower measurement performance.</p>
Vertical Exg.	0.5, 1, 2, 5 or 10	Vertical exaggeration for cross section plots. Vertical plot scale relative to horizontal.

Next step

PAGE (F6) changes to the **Logfile** page.

6.3.4

The Logfile Page

The Logfile page

Road Configuration [X]

General | Check | InfoAPI | Logfile

Write Logfile: **Yes**

File Name : logfile.txt

Format File :

Q2 a

CONT PAGE

CONT (F1)

To confirm the changes and move to the previous screen.

Field	Option	Description of Field
Write Logfile	Yes or No	Activates the generation of a logfile using the selected Format File and the storage of measured points. The logfile is generated when the application program is exited.
File Name	User input	Available for Write Logfile: Yes . The name of the file to which the data should be written. A logfile has the extension *.log and is stored in the \DATA directory of the active memory device. The data is always appended to the file. Opening the choicelist accesses XX Logfiles where a name for a new logfile can be created and an existing logfile can be selected or deleted.

Field	Option	Description of Field
Format File	Choicelist	Available for Write Logfile: Yes . A format file defines which and how data is written to a logfile. Format files are created using LGO. A format file must first be transferred from the CompactFlash card to the System RAM before it can be selected. Refer to the "Technical Reference Manual" for information on how to transfer a format file. Opening the choicelist accesses MANAGE Format Files where an existing format file can be selected or deleted.

Next step

CONT (F1) to accept the changes and continue.

6.4 Road Stake Out Info Page and Road Check Info Page

6.4.1 Overview

Description

Depending on the working method used on the construction site, different information is written on the stakes. RoadRunner displays the information to be written on the stake on the **Info** page. The **Info** page can be customised to display the required information for each stake out and check method.



Defining Info pages for RoadRunner follows the same philosophy used for display masks. Refer to the "Technical Reference Manual" for information on display masks.

Info pages

Road Check: Info Pages and corresponding Methods

Nr	Method	Info Page type	Description
1	Stringline	Check Strgl	Used for Stringline.
2	Individual Stringline	Check Ind Strgl	Used for Individual Stringline.
3	X-Slope	Check X-Slope	Used for X-Slope.
4	Slope Manual	Check Man Slp	Used for Slope manual.
5	Slope	Check Slope	Used for Slope.
6	Crown	Check Crown	Used for Crown.
7	Layer	Check Layer	Used for Layer.
8	DTM	Check DTM	Used for DTM.

Road Stake: Info Pages and corresponding Methods

Nr	Method	Info Page type	Description
1	Stringline	Stake Strgl	Used for Stringline.
2	Individual Stringline	Stake Ind Strgl	Used for Individual Stringline.
3	X-Slope	Stake X-Slope	Used for X-Slope.
4	Slope Manual	Stake Man Slp	Used for Slope Manual.
5	Slope	Stake Slope	Used for Slope.
6	Crown	Stake Crown	Used for Crown.
7	Layer	Stake Layer	Used for Layer.

6.4.2

Changing Display Items of the Info Page

Description

The different info pages are part of the road configuration.

Changing items step-by-step

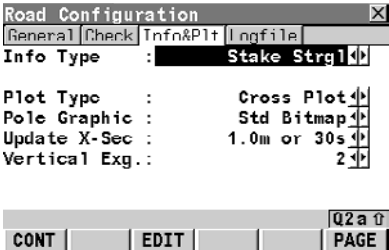
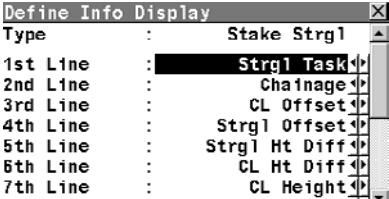
Step	Description
1.	Refer to "6.1 Overview of all Configuration Settings".
2.	Press PAGE (F6) until the Info&Plt page is active.
3.	<p>RR Road Configuration, Info&Plt page</p> <p>Choose the Info Type to change.</p> 
4.	<p>Press EDIT (F3) to move to RR Define Info Display. Modifying of the selected Info Type can now begin.</p> 

Next step

IF selected Info Type is	THEN
Check Strgl	refer to "6.4.3 Info Page for Stringline".
Check Ind Strgl	refer to "6.4.4 Info Page for Individual Stringline".
Check X-Slope	refer to "6.4.5 Info Page for X-Slope".
Check Man Slp	refer to "6.4.6 Info Page for Slope Manual and Slope".
Check Slope	refer to "6.4.6 Info Page for Slope Manual and Slope".
Check Crown	refer to "6.4.7 Info Page for Crown".
Check Layer	refer to "6.4.8 Info Page for Layer".
Check DTM	refer to "6.4.9 Info Page for DTM".
Stake Strgl	refer to "6.4.3 Info Page for Stringline".
Stake Ind Strgl	refer to "6.4.4 Info Page for Individual Stringline".
Stake X-Slope	refer to "6.4.5 Info Page for X-Slope".
Stake Man Slp	refer to "6.4.6 Info Page for Slope Manual and Slope".
Stake Slope	refer to "6.4.6 Info Page for Slope Manual and Slope".
Stake Crown	refer to "6.4.7 Info Page for Crown".
Stake Layer	refer to "6.4.8 Info Page for Layer".

6.4.3

Info Page for Stringline

Description

This info page is used for the following methods:

- Road Check **Stringline**
- Road Stake **Stringline**.



Access step-by-step

Step	Description
1.	Select Road Config in RR Configuration .
2.	Press PAGE (F6) until the Info&Plt page is active.
3.	RR Road Configuration, Info&Plt page Choose the Info Type to change: <ul style="list-style-type: none"> • for Road Check Info Type: Check Strgl • for Road Stake-Out Info Type: Stake Strgl
4.	Press EDIT (F3) to move to RR Define Info Display . Modifying of the selected Info Type can now begin.

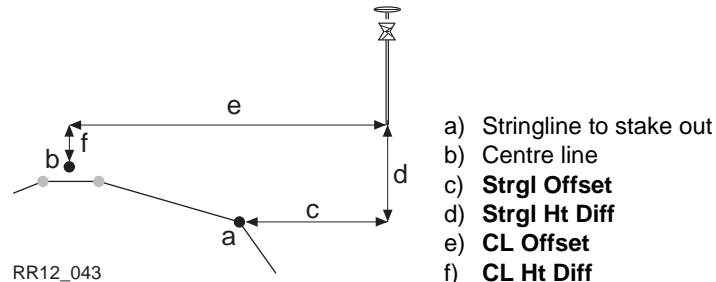
Available items



All fields from **RR Stake-Stringline, Stake** page are available for the **Info** page.

Field	Option	Description of Field
Strgl Task	Output	Name defined for the stringline/centre line task.
ΔOffset	Output	Horizontal offset between the defined position and the current position.  Refer to the different stake out methods for more details.
ΔHeight	Output	Vertical offset between the defined position and the current position.  Refer to the different stake out methods for more details.
ΔChainage	Output	Difference between the defined chainage def Chainage on the General page and the current chainage Chainage shown on the Stake page.  If no defined chainage exists, e.g. if staking out random chainages or checking, this field reads ΔChainage:---- .
Chainage	Output	The current chainage. This field is independent of the chosen Orientation and Guidance in Road Configuration .
def Chainage	Output	Chainage to stake-out.
Strgl Offset	Output	Horizontal offset from the stringline.
Strgl Ht Diff	Output	Height difference from the defined stringline.

Field	Option	Description of Field
Strgl Name	Output	Name of the stringline to stake out or the stake out is relative to.
CL Ht Diff	Output	Height difference from the centre line.
CL Height	Output	Height of the centre line at the current chainage.
CL Radius	Output	Radius of the centre line at the current chainage.
CL Type	Output	Curve type of the centre line.
CL Offset	Output	Perpendicular horizontal offset from the centre line. This field is independent of the chosen Orientation and Guidance in Road Configuration .
CL Tangent	Output	Tangent direction of the centre line at the current chainage.
Near Tang Pt	Output	Refer to "5.3 The Stake Page" for details on this field.
Vert Sqr Off	Output	Offset perpendicular to the vertical component of the centreline. This value may be useful when dealing with pipelines, cables and in the construction segment.
Vert Chainage	Output	Chainage the measured point is project to perpendicular to the vertical component of the centreline.

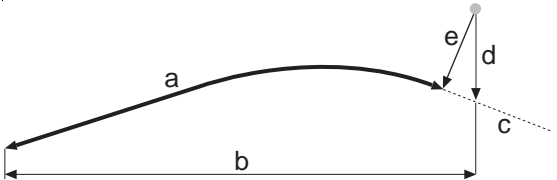
Field	Option	Description of Field
		 <p>RR12_089</p> <ul style="list-style-type: none"> a) Vertical chainage Vert Chainage b) Chainage Chainage c) Centreline d) Centreline height difference CL Ht Diff e) Vertical square offset Vert Sqr Off
CL Grade	Output	Grade of the centre line at the current position.
Dirc to Point	Output	Direction from the current position to the point to stake out.
Dist to Point	Output	Distance from the current position to the point to stake out.
Def Easting	Output	Easting of the point to stake out.
Def Northing	Output	Northing of the point to stake out.
Def Height	Output	Height of the point to stake out.
Act Easting	Output	Easting of the current position.
Act Northing	Output	Northing of the current position.
Act Height	Output	Height of the current position.

Field	Option	Description of Field
Curr Des Est	Output	Easting of the design for the current position (relevant point at the centreline).
Curr Des Nor	Output	Northing of the design for the current position (relevant point at the centreline).
Curr Des Hgt	Output	Height of the design for the current position (relevant point at the centreline).
Quality 3D	Output	The 3D coordinate quality of the point coordinates. Refer to "5.3 Point Management" of the "Technical Reference Manual" for detailed information.

Next step

CONT (F1) to confirm the changes and continue.

6.4.4

Info Page for Individual Stringline

Description

This info page is used for the following working methods:

- Road Check **Individual Stringline**.
- Road Stake **Individual Stringline**

Access step-by-step

Step	Description
1.	Select Road Config in RR Configuration .
2.	Press PAGE (F6) until the Info&Plt page is active.
3.	RR Road Configuration, Info&Plt page Choose the Info Type to change: <ul style="list-style-type: none">• for Road Check Info Type: Check Ind Strgl• for Road Stake-Out Info Type: Stake Ind Strgl
4.	Press EDIT (F3) to move to RR Define Info Display . Modifying of the selected Info Type can now begin.

Available items

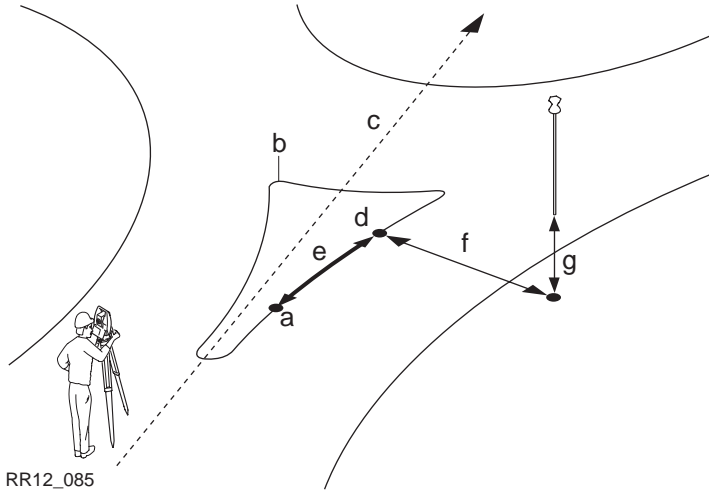



RR12_085

Stake Out of Roundabout

- a) Position to stake out
- b) Stringline to stake out
- c) Centreline
- d) Chainage**
- e) Δ Chainage**
- f) Δ Offset**
- g) Δ Height**

All fields from **RR Stake-Stringline, Stake** page are available for the **Info** page.

Field	Option	Description of Field
Strgl Task	Output	Name defined for the stringline/centre line task.
ΔOffset	Output	Horizontal offset between the defined position and the current position.  Refer to the different stake out methods for more details.
ΔHeight	Output	Vertical offset between the defined position and the current position.

Field	Option	Description of Field
		 Refer to the different stake out methods for more details.
ΔChainage	Output	Difference between the defined chainage def Chainage on the General page and the current chainage Chainage shown on the Stake page.  If no defined chainage exists, e.g. if staking out random chainages or checking, this field reads ΔChainage:---- .
Chainage	Output	The current chainage. This field is independent of the chosen Orientation and Guidance in Road Configuration .
def Chainage	Output	Chainage to stake-out.
Strgl Offset	Output	Horizontal offset from the stringline.
Strgl Ht Diff	Output	Height difference from the defined stringline.
Strgl Name	Output	Name of the stringline to stake out or the stake out is relative to.
CL Ht Diff	Output	Height difference from the centre line.
CL Height	Output	Height of the centre line at the current chainage.
CL Radius	Output	Radius of the centre line at the current chainage.
CL Type	Output	Curve type of the centre line.

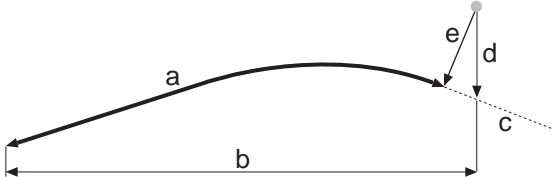
Field	Option	Description of Field
CL Offset	Output	Perpendicular horizontal offset from the centre line. This field is independent of the chosen Orientation and Guidance in Road Configuration .
CL Tangent	Output	Tangent direction of the centre line at the current chainage.
Near Tang Pt	Output	Refer to "5.3 The Stake Page" for details on this field.
Vert Sqr Off	Output	Offset perpendicular to the vertical component of the centreline. This value may be useful when dealing with pipelines, cables and in the construction segment.
Vert Chainage	Output	<p>Chainage the measured point is project to perpendicular to the vertical component of the centreline.</p>  <p>RR12_089</p> <ul style="list-style-type: none"> a) Vertical chainage Vert Chainage b) Chainage Chainage c) Centreline d) Centreline height difference CL Ht Diff e) Vertical square offset Vert Sqr Off

Field	Option	Description of Field
CL Grade	Output	Grade of the centre line at the current position.
Dirc to Point	Output	Direction from the current position to the point to stake out.
Dist to Point	Output	Distance from the current position to the point to stake out.
Def Easting	Output	Easting of the point to stake out.
Def Northing	Output	Northing of the point to stake out.
Def Height	Output	Height of the point to stake out.
Act Easting	Output	Easting of the current position.
Act Northing	Output	Northing of the current position.
Act Height	Output	Height of the current position.
Curr Des Est	Output	Easting of the design for the current position (relevant point at the stringline).
Curr Des Nor	Output	Northing of the design for the current position (relevant point at the stringline).
Curr Des Hgt	Output	Height of the design for the current position (relevant point at the stringline).
Hgt EndVAlign	Output	Height at the endpoint of the vertical alignment of the stringline.
ΔHt EndVAlign:	Output	Height difference to the endpoint of the vertical alignment of the stringline.

Field	Option	Description of Field
Quality 3D	Output	The 3D coordinate quality of the point coordinates. Refer to "5.3 Point Management" of the "Technical Reference Manual" for detailed information.

Next step

CONT (F1) to confirm the changes and continue.

Working with pipelines

Description

When staking/checking pipes a common task is to use height differences to the start/end of the pipe. The two Info page items for individual Stringlines enable you to add the height difference to the end of the vertical alignment (**Δ Ht EndVAlign**) as well as the height of the end of the vertical alignment (**Ht EndVAlign**).

Screen

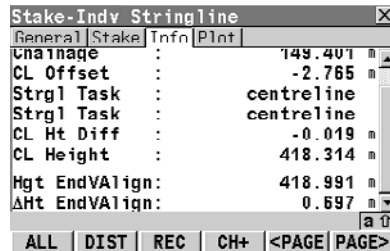

6.4.5

Info Page for X-Slope

Description

This info page is used for the following working methods:

- Road Check **X-Slope**.
- Road Stake **X-Slope**

Access step-by-step

Step	Description
1.	Select Road Config in RR Configuration .
2.	Press PAGE (F6) until the Info&Plt page is active.
3.	RR Road Configuration, Info&Plt page Choose the Info Type to change: <ul style="list-style-type: none">• for Road Check Info Type: Check X-Slope• for Road Stake-Out Info Type: Stake X-Slope
4.	Press EDIT (F3) to move to RR Define Info Display . Modifying of the selected Info Type can now begin.

Available items

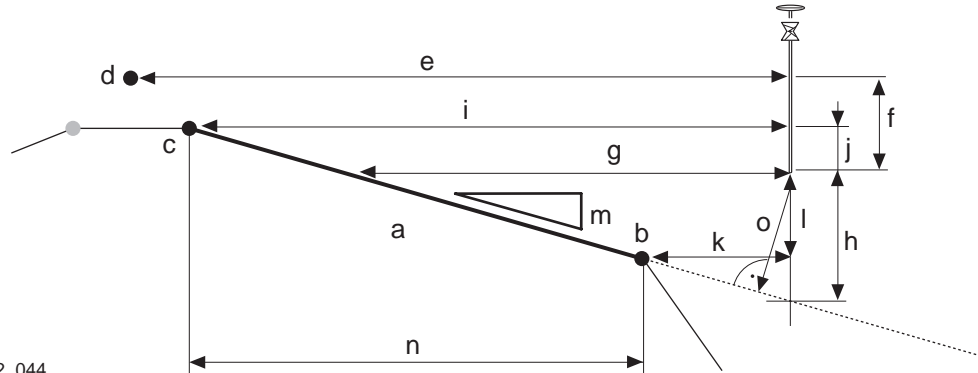



RR12_044

- a) X-slope to stake out
- b) Right stringline of the X-slope **Right Name**
- c) Left stringline of the X-slope **Left Name**
- d) Centre line
- e) **CL Offset**
- f) **CL Ht Diff**
- g) **X-Slp Offset**
- h) **X-Slp Ht Diff**
- i) **Left Offset**
- j) **Left Ht Diff**
- k) **Right Offset**
- l) **Right Ht Diff**
- m) **Slope Ratio**
- n) **Width**
- o) **Square Off**

All fields from **RR Stake-X-Slope, Stake** page are available for the **Info** page.

Field	Option	Description of Field
X-Slope Task	Output	Name defined for the X-slope task.
ΔOffset	Output	Horizontal offset between the defined position and the current position.  Refer to the different stake out methods for more details.

Field	Option	Description of Field
ΔHeight	Output	Vertical offset between the defined position and the current position.  Refer to the different stake out methods for more details.
ΔChainage	Output	Difference between the defined chainage def Chainage on the General page and the current chainage Chainage shown on the Stake page.  If no defined chainage exists, e.g. if staking out random chainages or checking, this field reads ΔChainage:---- .
Chainage	Output	The current chainage. This field is independent of the chosen Orientation and Guidance in Road Configuration .
def Chainage	Output	Chainage to stake-out.
X-Slp Offset	Output	Horizontal offset from the X-slope.
X-Slp Ht Diff	Output	Height difference to the X-slope. If no stake height difference is used X-Slp Ht Diff = ΔHeight .
Left Name	Output	Name of the left stringline defining the X-slope.
Left Offset	Output	Horizontal offset from the left point of the X-slope.
Left Ht Diff	Output	Height difference from the left point of the X-slope.
Right Name	Output	Name of the right stringline defining the X-slope.
Right Offset	Output	Horizontal offset from the right point of the X-slope.

Field	Option	Description of Field
Right Ht Diff	Output	Height difference from the right point of the X-slope.
Ref Line	Output	Indicates which side of the X-slope the stake out is relative to.
Ref Offset	Output	Horizontal offset from the stringline of the X-slope used as reference. Depends on Ref Line and is identical to Right Offset or Left Offset .
Ref Ht Diff	Output	Height difference from the stringline of the X-slope used as reference. Depends on Ref Line and is identical to Right Ht Diff or Left Ht Diff .
X-Slope Ratio	Output	Slope ratio of the X-slope.
Square Offset	Output	Offset from the X-slope, perpendicular to the X-slope.
CL Ht Diff	Output	Height difference from the centre line.
CL Height	Output	Height of the centre line at the current chainage.
CL Radius	Output	Radius of the centre line at the current chainage.
CL Type	Output	Curve type of the centre line.
CL Offset	Output	Perpendicular horizontal offset from the centre line. This field is independent of the chosen Orientation and Guidance in Road Configuration .
CL Tangent	Output	Tangent direction of the centre line at the current chainage.
Width	Output	Horizontal width of the X-slope.
Near Tang Pt	Output	Refer to "5.3 The Stake Page" for details on this field.

Field	Option	Description of Field
CL Grade	Output	Grade of the centre line at the current position.
Dirc to Point	Output	Direction from the current position to the point to stake out.
Dist to Point	Output	Distance from the current position to the point to stake out.
Def Easting	Output	Easting of the point to stake out.
Def Northing	Output	Northing of the point to stake out.
Def Height	Output	Height of the point to stake out.
Act Easting	Output	Easting of the current position.
Act Northing	Output	Northing of the current position.
Act Height	Output	Height of the current position.
Curr Des Est	Output	Easting of the design for the current position (relevant point on the X-Slope = Act Easting).
Curr Des Nor	Output	Northing of the design for the current position relevant point on the X-Slope = Act Northing).
Curr Des Hgt	Output	Height of the design for the current position (relevant point on the X-Slope).

Next step

CONT (F1) to confirm the changes and continue.

6.4.6

Info Page for Slope Manual and Slope

Description

This info page is used for the following working methods:

- Road Check **Slope Manual, Slope.**
- Road Stake **Slope Manual, Slope.**

Access step-by-step

Step	Description
1.	Select Road Config in RR Configuration .
2.	Press PAGE (F6) until the Info&Plt page is active.
3.	RR Road Configuration, Info&Plt page Choose the Info Type to change: <ul style="list-style-type: none"> • for Road Check Info Type: Check Man Slope, Info Type: Check Slope • for Road Stake-Out Info Type: Stake Man Slope, Info Type: Stake Slope
4.	Press EDIT (F3) to move to RR Define Info Display . Modifying of the selected Info Type can now begin.

Available items

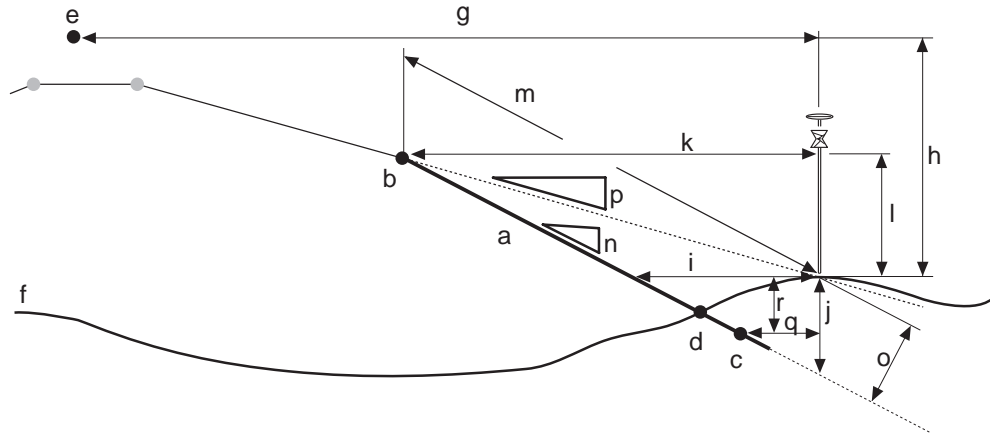





RR12_045

- | | | |
|--|------------------|------------------|
| a) Slope to stake out/check | g) CL Offset | n) Slope Ratio |
| b) Hinge point Hinge Name | h) CL Ht Diff | o) Square Offset |
| c) Second stringline of slope
2nd Name | i) Slope Offset | p) Current Ratio |
| d) Real catch point | j) Slope Ht Diff | q) 2nd Offset |
| e) Centre line | k) Hinge Offset | r) 2nd Ht Diff |
| f) Natural surface | l) Hinge Ht Diff | |
| | m) Slope Dist Hg | |

All fields from **RR Stake-Slope, Stake** page are available for the **Info** page.

Field	Option	Description of Field
Slope Task	Output	Name defined for the slope task.

Field	Option	Description of Field
ΔOffset	Output	Horizontal offset between the defined position and the current position.  Refer to the different stake out methods for more details.
ΔHeight	Output	Vertical offset between the defined position and the current position.  Refer to the different stake out methods for more details.
ΔChainage	Output	Difference between the defined chainage def Chainage on the General page and the current chainage Chainage shown on the Stake page.  If no defined chainage exists, e.g. if staking out random chainages or checking, this field reads ΔChainage:---- .
Chainage	Output	The current chainage. This field is independent of the chosen Orientation and Guidance in Road Configuration .
def Chainage	Output	Chainage to stake-out.
Slope Offset	Output	Horizontal offset from the slope.
Slope Ht Diff	Output	Height difference from the slope. If no stake height difference is used Slope Ht Diff = ΔHeight .
Ht Diff Rail	Output	Height difference from the batter rail to mark the slope (for Slope Method: Batter Rail).

Field	Option	Description of Field
Hinge Name	Output	Name of the stringline defining the hinge of the slope.
Hinge Offset	Output	Horizontal offset from the hinge point of the slope.
Hinge Ht Diff	Output	Height difference from the hinge point of the slope.
2nd Name	Output	Name of the second stringline defining the slope.
2nd Offset	Output	Horizontal offset from the second stringline of the slope.
2nd Ht Diff	Output	Height difference from the second stringline of the slope.
Slope Ratio	Output	Ratio of the slope.  The display format depends on the type chosen for Slope Format on the Project Configuration, General page.
Slope Dist Hg	Output	Slope distance to the hinge point.  All defined settings for a batter rail or reference point are already taken into account. This is the information to write on the stake.
Slope Rat Gon	Output	Slope ratio in gon.
Slope Rat Deg	Output	Slope ratio in decimal degrees.
Slope Rat %	Output	Slope ratio in percent.
Current Ratio	Output	Ratio of the slope from the current position to the hinge.

Field	Option	Description of Field
		 For the catch point the Actual Ratio is identical to the Slope Ratio .
Square Offset	Output	Offset from the slope, perpendicular to the slope.
CL Ht Diff	Output	Height difference from the centre line.
CL Height	Output	Height of the centre line at the current chainage.
CL Radius	Output	Radius of the centre line at the current chainage.
CL Type	Output	Curve type of the centre line.
CL Offset	Output	Perpendicular horizontal offset from the centre line. This field is independent of the chosen Orientation and Guidance in Road Configuration .
CL Tangent	Output	Tangent direction of the centre line at the current chainage.
Traveler Ht	Output	Height of the traveller in use. Refer to "11.7 Methods for Slope Staking" for information on the different methods of slope staking.
Near Tang Pt	Output	Refer to "5.3 The Stake Page" for details on this field.
CL Grade	Output	Grade of the centre line at the current position.
Dirc to Point	Output	Direction from the current position to the point to stake out.
Dist to Point	Output	Distance from the current position to the point to stake out.
Def Easting	Output	Easting of the point to stake out.

Field	Option	Description of Field
Def Northing	Output	Northing of the point to stake out.
Def Height	Output	Height of the point to stake out.
Act Easting	Output	Easting of the current position.
Act Northing	Output	Northing of the current position.
Act Height	Output	Height of the current position.
Curr Des Est	Output	Easting of the design for the current position (relevant point on the X-Slope = Act Easting).
Curr Des Nor	Output	Northing of the design for the current position relevant point on the X-Slope = Act Northing).
Curr Des Hgt	Output	Height of the design for the current position (relevant point on the slope).
Quality 3D	Output	The 3D coordinate quality of the point coordinates. Refer to "5.3 Point Management" of the "Technical Reference Manual" for detailed information.

Next step

CONT (F1) to confirm the changes and continue.

6.4.7

Info Page for Crown

Description

This info page is used for the following working methods:

- Road Check **Crown**.
- Road Stake **Crown**

Access step-by-step

Step	Description
1.	Select Road Config in RR Configuration .
2.	Press PAGE (F6) until the Info&Plt page is active.
3.	RR Road Configuration, Info&Plt page Choose the Info Type to change: <ul style="list-style-type: none">• for Road Check Info Type: Check Crown• for Road Stake-Out Info Type: Stake Crown
4.	Press EDIT (F3) to move to RR Define Info Display . Modifying of the selected Info Type can now begin.

Available items

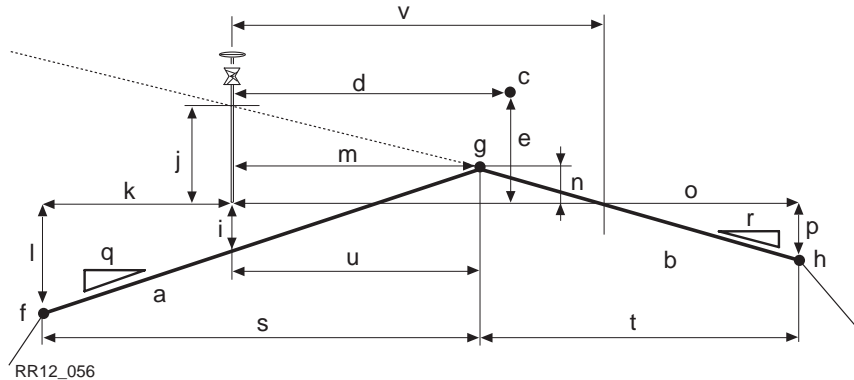

RR12_056

- | | | |
|--------------------------------------|---------------------------------------|-------------------------|
| a) Left X-slope of road crown | h) Right most stringline of the crown | p) Right Ht Diff |
| b) Right X-slope of road crown | i) Left XS Ht D | q) L X-Slp Ratio |
| c) Centre line | j) Right XS Ht D | r) R-X-Slp Ratio |
| d) CL Offset | k) Left Offset | s) Left Width |
| e) CL Ht Diff | l) Left Ht Diff | t) Right Width |
| f) Left most stringline of the crown | m) Mid Offset | |
| g) Middle stringline of the crown | n) Mid Ht Diff | |
| | o) Right Offset | |

All fields from **RR Stake-Crown, Stake** page are available for the **Info** page.

Field	Option	Description of Field
Crown Task	Output	Name defined for the road crown task.

Field	Option	Description of Field
ΔOffset	Output	Horizontal offset to the stringline of the crown defined as the reference line. If working in the zig zag mode, RoadRunner automatically selects the correct stringline as the reference depending on whether the measured point is to the left or right of the middle stringline. Refer to "4.11 The Zig Zag Mode" for more information on the zig zag mode.
ΔHt Left	Output	Vertical offset to the left/right X-slope defining the road crown.
ΔHt Right	Output	Vertical offset to the left/right X-slope defining the road crown.
ΔChainage	Output	Difference between the defined chainage def Chainage on the General page and the current chainage Chainage shown on the Stake page.  If no defined chainage exists, e.g. if staking out random chainages or checking, this field reads ΔChainage:---- .
Chainage	Output	The current chainage. This field is independent of the chosen Orientation and Guidance in Road Configuration .
def Chainage	Output	Chainage to stake-out.
Left XS Ht D	Output	Height difference from the road crowns left X-slope.
Right XS Ht D	Output	Height difference from the road crowns right X-slope.

Field	Option	Description of Field
Ht Diff Crown	Output	Height difference from Active X-Slp of the crown.
Active X-Slp	Output	Indicates if you are on the left or right X-slope of the road crown.
Active XS Rat	Output	Slope ratio of Active X-Slp . This value is equal to L X-Slp Ratio or R X-Slp Ratio depending on the value of Active X-Slp .
Left Name	Output	Name of the left most stringline defining the road crown.
Left Offset	Output	Horizontal offset from the left stringline of the road crown.
Left Ht Diff	Output	Height difference from the left stringline of the road crown.
Right Name	Output	Name of the left most stringline defining the road crown.
Right Offset	Output	Horizontal offset from the right stringline of the road crown.
Right Ht Diff	Output	Height difference from the right stringline of the road crown.
Mid Name	Output	Name of the mid stringline defining the road crown.
Mid Offset	Output	Horizontal offset from the mid stringline of the road crown.
Mid Ht Diff	Output	Height difference from the mid stringline of the road crown.

Field	Option	Description of Field
L X-Slp Ratio	Output	Slope ratio of the road crowns left X-slope.
R X-Slp Ratio	Output	Slope ratio of the road crowns right X-slope.
Left Width	Output	Horizontal width of the road crowns left X-slope.
Right Width	Output	Horizontal width of the road crowns right X-slope.
CL Ht Diff	Output	Height difference from the centre line.
CL Height	Output	Height of the centre line at the current chainage.
CL Radius	Output	Radius of the centre line at the current chainage.
CL Type	Output	Curve type of the centre line.
CL Offset	Output	Perpendicular horizontal offset from the centre line. This field is independent of the chosen Orientation and Guidance in Road Configuration .
CL Tangent	Output	Tangent direction of the centre line at the current chainage.
Near Tang Pt	Output	Refer to "5.3 The Stake Page" for details on this field.
CL Grade	Output	Grade of the centre line at the current position.
Dirc to Point	Output	Direction from the current position to the point to stake out.
Dist to Point	Output	Distance from the current position to the point to stake out.
Def Easting	Output	Easting of the point to stake out.
Def Northing	Output	Northing of the point to stake out.

Field	Option	Description of Field
Def Height	Output	Height of the point to stake out.
Act Easting	Output	Easting of the current position.
Act Northing	Output	Northing of the current position.
Act Height	Output	Height of the current position.
Curr Des Est	Output	Easting of the design for the current position (relevant point on the crown = Act Easting).
Curr Des Nor	Output	Northing of the design for the current position relevant point on the crown = Act Northing).
Curr Des Hgt	Output	Height of the design for the current position (relevant point on the crown).

Next step

CONT (F1) to confirm the changes and continue.

6.4.8

Info Page for Layer

Description

This info page is used for the following working methods:

- Road Check **Layer**.
- Road Stake **Layer**

Access step-by-step

Step	Description
1.	Select Road Config in RR Configuration .
2.	Press PAGE (F6) until the Info&Plt page is active.
3.	RR Road Configuration, Info&Plt page Choose the Info Type to change: <ul style="list-style-type: none">• for Road Check Info Type: Check Layer• for Road Stake-Out Info Type: Stake Layer
4.	Press EDIT (F3) to move to RR Define Info Display . Modifying of the selected Info Type can now begin.

Available items

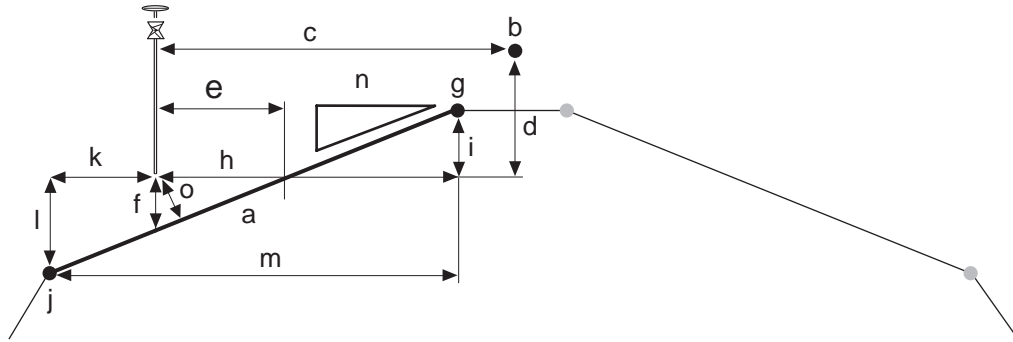



RR12_047

- | | | |
|-------------------------------|-------------------------|--|
| a) Relevant part of the layer | g) Right Name | m) Width |
| b) Centre line | h) Right Offset | n) Slope Ratio or X-Slope Ratio |
| c) CL Offset | i) Right Ht Diff | o) Square Off |
| d) CL Ht Diff | j) Left Name | |
| e) Slope Offset | k) Left Offset | |
| f) Layer Ht Diff | l) Left Ht Diff | |

All fields from **RR Stake-Layer, Stake** page are available for the **Info** page.

Field	Option	Description of Field
Layer Task	Output	Name defined for the layer task.
Layer Name	Output	Name of the layer to check.
Chainage	Output	Chainage of the current measured position.

Field	Option	Description of Field
ΔChainage	Output	Difference between the defined chainage def Chainage on the General page and the current chainage Chainage shown on the Stake page.  If no defined chainage exists, e.g. if staking out random chainages or checking, this field reads ΔChainage:---- .
def Chainage	Output	Chainage to stake-out.
Layer Offset	Output	Horizontal offset from the layer. Surface between the left line Left Line and the right line Right Line .
Layer Ht Diff	Output	Height difference to the layer.
ΔHeight	Output	Height difference to the layer.
Left Name	Output	Name of the stringline next to the current position on the left hand side.
Left Offset	Output	Horizontal offset from the left stringline Left Name .
Left Ht Diff	Output	Height difference to the left stringline Left Name .
Right Name	Output	Name of the stringline next to the current position on the right hand side.
Right Offset	Output	Horizontal offset from the right stringline Right Name .
Right Ht Diff	Output	Height difference to the right stringline Right Name .
Slope Ratio	Output	Ratio of the slope between the left stringline Left Name and the right stringline Right Name .

Field	Option	Description of Field
		 The display format of the Slope Ratio depends on the type chosen for Slope Format on Project Configuration, General page.
X-Slope Ratio	Output	Ratio of the X-slope between the left stringline Left Name and the right stringline Right Name .  The display format of the X-Slope Rat depends on the type chosen for X-Slope Format on Project Configuration, General page.
Square Offset	Output	Offset from the slope, perpendicular to the slope.
CL Ht Diff	Output	Height difference from the centre line.
CL Height	Output	Height of the centre line at the current chainage.
CL Radius	Output	Radius of the centre line at the current chainage.
CL Type	Output	Curve type of the centre line.
CL Offset	Output	Horizontal offset from the centre line at the current chainage.
CL Tangent	Output	Tangent direction of the centre line at the current chainage.
Near Tang Pt	Output	Refer to "5.3 The Stake Page" for details on this field.
CL Grade	Output	Grade of the centre line at the current position.
Act Easting	Output	Easting of the current position.
Act Northing	Output	Northing of the current position.

Field	Option	Description of Field
Act Height	Output	Height of the current position.
Curr Des Est	Output	Easting of the design for the current position (relevant point on the layer = Act Easting).
Curr Des Nor	Output	Northing of the design for the current position relevant point on the layer = Act Northing).
Curr Des Hgt	Output	Height of the design for the current position (relevant point on the layer).

Next step

CONT (F1) to confirm the changes and continue.

6.4.9

Info Page for DTM

Description

This info page is used for the following working methods:

- Road Check **DTM**.

Access step-by-step

Step	Description
1.	Select Road Config in RR Configuration .
2.	Press PAGE (F6) until the Info&Plt page is active.
3.	RR Road Configuration, Info&Plt page Choose the Info Type to change: <ul style="list-style-type: none">• for Road Check Info Type: Check DTM
4.	Press EDIT (F3) to move to RR Define Info Display . Modifying of the selected Info Type can now begin.

Available items

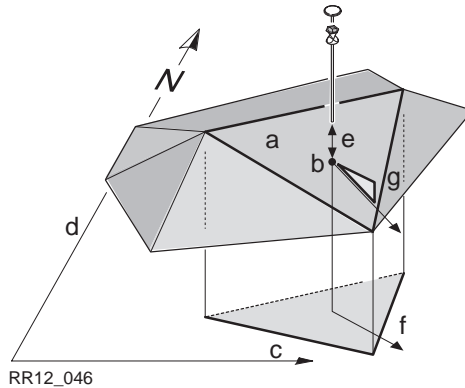

- a) Relevant triangle of the DTM
- b) Projected point on DTM
- c) Easting
- d) Northing
- e) **DTM Ht Diff**
- f) **Flow Directn**
- g) **Flow Ratio**

Field	Option	Description of Field
DTM Task	Output	Name defined for the DTM task.
DTM Ht Diff	Output	Vertical height difference to the DTM.
ΔHeight	Output	Height difference to the layer.
DTM Height	Output	Height of the DTM at the current measured position.
Flow Directn	Output	Direction of maximum slope ratio on the current DTM triangle. This is the direction water would flow towards from the projected point.
Flow Ratio	Output	Slope ratio of the DTM. This is the maximum slope ratio of the triangle.
DTM Name	Output	Name of the DTM surface.
Act Easting	Output	Easting of the current position.

Field	Option	Description of Field
Act Northing	Output	Northing of the current position.
Act Height	Output	Height of the current position.
Curr Des Est	Output	Easting of the DTM for the current position (= Act Easting).
Curr Des Nor	Output	Northing of the DTM for the current position (= Act Northing).
Curr Des Hgt	Output	Height of the DTM for the current position.
Quality 3D	Output	The 3D coordinate quality of the point coordinates. Refer to "5.3 Point Management" of the "Technical Reference Manual" for detailed information.

Next step

CONT (F1) to confirm the changes and continue.

6.5 Auto Positioning (TPS only)

6.5.1 Overview

Description

To make stake out of points even more efficient a motorised instrument offers you the possibility to automatically aim to the stake out position. Various auto positioning methods are available:

Type	Description
2D	The instrument positions horizontally in the direction of the point to stake out.
3D	The instrument positions horizontally and vertically to the point to stake out.
2D + Meas	Positions the instrument using iterative measurements.
Advance	Offers the possibility of fixing certain stake out values.

When using the **3D** method the instrument will only point to the correct position on the ground if the point to stake out has the same height as the natural surface. If the natural surface is higher than the point to stake out, the measured point would be closer than the stake out point. If the natural surface is lower than the point, the measured point would be further away.

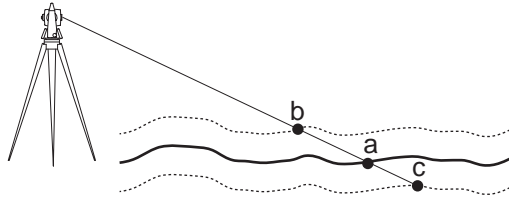

RR12_071

- a) Point to stake out, defined with 3D coordinates
- b) Position if natural surface is higher than point to stake out
- c) Position if natural surface is lower than point to stake out

To avoid this problem RoadRunner offers the possibility of iterative positioning using the auto position method **2D + Meas.**

6.5.2

Auto Position 2D + Measure

Description

This auto position method **2D + Meas** allows the instrument to aim at a 2D position. As the natural surface height is unknown the correct position is calculated via iterations.

Workflow

The first position (b) the instrument points to is defined by the 2D coordinates (a) of the point to stake out (= horizontal direction) and the current vertical angle. Therefore, aim the instrument at the approximate position of the point to stake out.

RoadRunner then compares the measured 2D position with the stake out position to determine a new position (c) to aim at. As no information about the natural surface is available, RoadRunner calculates a point at the same height as the measured position. The new position (d) is measured and compared again with the point to stake out (a).

This iteration process runs until the tolerances defined for the stake out are reached.

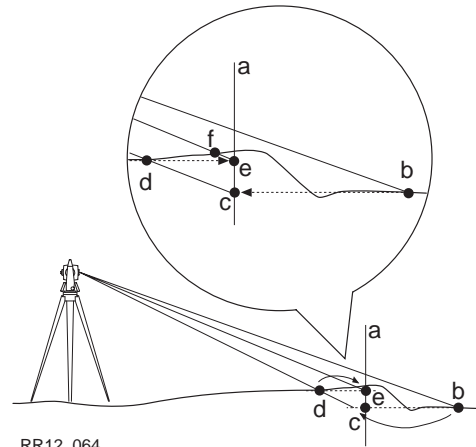



RR12_064

- a) 2D position to stake out
- b) First position measured defined by 2D coordinates and current vertical angle
- c) New position calculated based on height of b
- d) Second position measured
- e) New position calculated base on height of d. The measured position for this point is within the defined tolerance, the correct position is found.

Depending on the settings chosen on **RR Configuration, Posit** page the instrument will turn on the red laser as soon as the position is found.

Auto position step-by-step

Step	Description
1.	Select Project Config in RR Configuration .
2.	Press PAGE (F6) until the Posit page is active.
3.	RR Configuration, Posit page. Choose Auto Position: 2D + Meas.
	Make sure that the instrument uses the reflectorless EDM mode.
4.	As the instrument uses the current vertical angle for the first iteration aim the instrument at the position you expect the point to stake out.
5.	Press SHIFT POSIT (F4) to start the iterative positioning of the instrument.
	The instrument spins to the horizontal direction and uses the current vertical angle for the first iteration. As soon as the defined Position Tol from RR Configuration, Posit is reached, the instrument stops.
	Depending on the settings chosen on RR Configuration, Posit page, the instrument turns on the red laser to mark the height.

6.5.3

Auto Position Advanced

Description

The advanced option for auto positioning allows you to let the instrument aim at positions with certain parameters fixed. For example, let the instrument find the height on the peg.

Auto position step-by-step

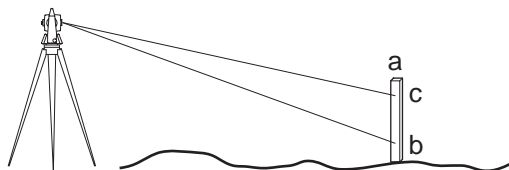

In this example, the height of the X-slope should be marked on a peg by using the auto position function.



RR12_072

- a) Peg placed at the correct position
- b) First height, manually chosen direction
- c) Required height on the peg

Step	Description
1.	Select Project Config in RR Configuration .
2.	Press PAGE (F6) until the Posit page is active.
3.	RR Configuration, Posit page. Choose Auto Position: Advanced .
	Make sure that the instrument uses the reflectorless EDM mode.
4.	After stake out of the peg at the correct position with RR Stake X-Slope aim the instrument at the peg.
5.	Press SHIFT POSIT (F4) to start the iterative positioning of the instrument.
6.	RR Auto Position

Step	Description
	Highlight Height (Dir = fixed) .
7.	Press CONT (F1)
	The instrument will search for the point on the peg at the required height without changing the horizontal direction.
	As soon as the defined Height Tol from RR Configuration, Posit is reached, the instrument stops. Refer to "6.5 Auto Positioning (TPS only)" for more information.
	Depending on the settings chosen on RR Configuration, Posit page, the instrument turns on the red laser to mark the height.

7

Managing the Project

7.1

Overview

Description

- Working on a construction site implies working with various data such as:
 - Control points as reference
 - Data for road stake out
 - Measurement data
 - DTM's etc.
- To avoid having to select individual data sets each time the application is used, data can be grouped into projects. This makes the selection much easier and reduces the risk of selecting wrong data set.

Project

- A project consists of different kinds of jobs that belong together. By selecting a project automatically all referenced jobs are selected as well. A project can reference:
 - one fixpoint job
 - one measurement job
 - one road job
 - one DTM job.
- Since jobs are just referenced by a project, they can be used in more than one RoadRunner project, as well as in other applications. For example the same collection of control points may be used in two different projects.

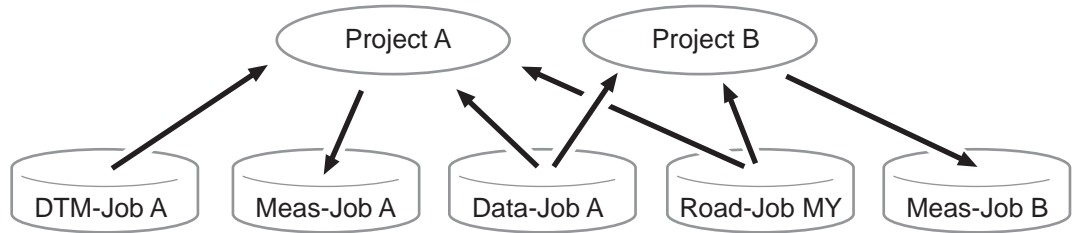

RR12_028

Project A and Project B reference the same fixpoint job (Data-Job A) and road job (Road-Job MY), however, their results are stored into different measurement jobs (Meas-Job A; Meas-Job B).

Fixpoint job

The fixpoint job holds all control point information needed in the field. Control points are, for example, points with known coordinates used for a TPS set-up or points used to determine a GPS coordinate system. The fixpoint job is a source of information. Data is read from it, but not written to it.

Measurement job

The measurement job is where information generated in the field is recorded. All measurements, points and other values stored in the field are added to this job.

Road job

All road design information, either typed in manually or exported from a design package is stored in the road job. Like the fixpoint job, it is a source of information. Refer to "8 Managing the Road Job" for more information on road jobs.

DTM job

Holds DTM or TIN data (**D**igital **T**errain **M**odel; **T**riangular **I**rrregular **N**etwork). Like a fixpoint job or road job, the DTM job is a source of information. Refer to "8.6 Working with a DTM Job" for more information on DTM jobs.



The same job can be used as a fixpoint and measurement job.



Road jobs and DTM jobs cannot be selected as a fixpoint or a measurement job. When selecting a job, a filter is applied to show only the relevant jobs in the selection list.

7.2

Selecting a Project from Task Management

Accessing the screens

Highlight the Project on the RoadRunner Setup screen and press ENTER.

RR Projects (Device)

Projects (CF Card)	
Name	Date
Road Project	17.11.06
RoadRunnerRail	13.07.06
RoadRunner	07.08.06
Tunnel Project	20.11.06

Q2a ↑

CONT	NEW	EDIT	DEL	MORE	INTL
------	-----	------	-----	------	------

CONT (F1)

To select the highlighted project and to continue.

NEW (F2)

To create a new project.

Refer to "7.4 Creating a New Project".

EDIT (F3)

To edit the highlighted project. This project also becomes the active project.

Refer to "7.5 Editing an Existing Project".

DEL (F4)

To delete the highlighted project.

Refer to "7.6 Deleting an Existing Project"

MORE (F5)

To toggle between the project date and project time.

CFCD (F6) or INTL (F6)

To switch between the CompactFlash card and internal memory as the active device.

SHIFT TIME/NAME (F5)

To sort the list by time or name.

7.3 Selecting a Project by Resuming the Last Task (Advanced Mode)

Description

RoadRunner remembers the last active task used on the project. When the application is resumed, the last active task is remembered and can be accessed again. This avoids the selection of project, method and task to be staked out or checked every time after turning off the instrument.

Accessing the screens

Press RESUM (F4) on the RoadRunner Begin screen.

7.4

Creating a New Project

Accessing the screens

Press **NEW (F2)** on the RoadRunner Projects screen.

Description

Projects group the different kinds of jobs to give fast access and manage complex sites.

Create a project step-by-step

Step	Description
1.	Press NEW (F2) in Projects Management.
2.	RR New Project, General page. Define the following: <ul style="list-style-type: none">• Name (This field is mandatory),• Description,• Creator and• Device for the project.
3.	Press PAGE (F6) changes to the Jobs page.
4.	RR New Project, Jobs page. Choose the following jobs to be used in the new project: <ul style="list-style-type: none">• Fixpoint Job,• Meas Job,• Road Job and• DTM Job. It is possible to add or remove jobs to the project at a later stage.
5.	Press STORE (F1) to accept the changes and continue.

7.5 Editing an Existing Project

Accessing the screens

Highlight the desired project and press EDIT (F3) on the RoadRunner Projects screen.

Description

The project details contain general information about the project as well as the list of jobs referenced by the project.

RR

Edit Project Job Name, General page

```

Edit Project: RoadRunner
-----
General | Jobs
Name      : RoadRunner
Description : Tutorial
          : -----
Creator   : Your Name
Device    : CF Card
    
```

```

          | Q2 a ↑
STORE | | | | | PAGE
    
```

STORE (F1)

To accept changes and continue.

Field	Option	Description of Field
Name	User input	Project name, must be unique. This field is mandatory.
Description	User input	Two line description of the project.
Creator	User input	Name of the creator of the project.
Device	CF Card or Internal Memory	The device on which the job is stored.

Next step

PAGE (F6) changes to the Jobs page.

RR

Edit Project: Job Name,
Jobs page

Q2 a

STORE (F1)

To accept changes and continue.

Field	Option	Description of Field
Fixpoint Job	Choicelist	The job that contains the point data to be used.
Meas Job	Choicelist	The active job which also determines the coordinate system. Points which are occupied in staking out or check are stored in this job. The data from this job is shown in MANAGE Data: Job Name .
Road Job	Choicelist	The active road job. Refer to "8 Managing the Road Job".
DTM Job	Choicelist	The active DTM job. DTM jobs may be created in LGO. Refer to "8.6 Working with a DTM Job".

Next step

CONT (F1) to accept the changes and continue.



Selecting a **Fixpoint Job** and a **Meas Job** is mandatory.



Every job selection will bring up only the jobs that are valid. For example, the list of **Road Job** is different to the one for **Meas Job** and **Fixpoint Job**.

7.6 Deleting an Existing Project

Accessing the screens

Highlight the desired project and press DEL (F4) on the RoadRunner Projects screen.

Description

Deleting a project will not delete the measurement job, fixpoint job, road job and DTM job that it references.



If two projects use the same control points by referencing the same fixpoint job, deleting one project will not delete the control points for the other project.

Delete project step-by-step

Step	Description
1.	RR Projects (Device name). Highlight the project to delete.
2.	Press DEL (F4) to delete the project.

Next step

CONT (F1) to accept changes and continue.

8**Managing the Road Job**

8.1**Overview**

Two parts

Each road job consists of two major parts:

- **Design data:** Contain all the information about the road design. For example, the geometry of the centre line or the formation layer of the road. These data are either typed in manually or converted from a road design package. Refer to "8.4 Creating a New Road Job" for information on how to create road jobs.
- **Working tasks:** Define how the different elements of the road design are used within the stake out or check situations. For example, the same edge of the road is staked out once to define the shoulder and a second time with a certain offset as the gutter. Refer to "4 Step 3 - Working in Advanced mode" for more information on tasks.

Tasks define how the design elements of the road are staked out or checked in the field.

8.2

Working with the Design Data (Stringlines and Layers)

Description

Depending on the complexity of the road job, the design data may vary from being a single horizontal alignment to a design containing profiles with dozens of defined vertices. RoadRunner offers the possibility of grouping these design elements logical for faster access.

Stringlines

When manually typing in a road job, alignments and cross sections are used. Alignments are defined by geometric elements, for example straights and arcs, and the cross sections by vertices. Furthermore, one defines at which chainage a certain cross section is used. By doing this the vertices are connected to create a series of lines representing the three dimensional design of the road.

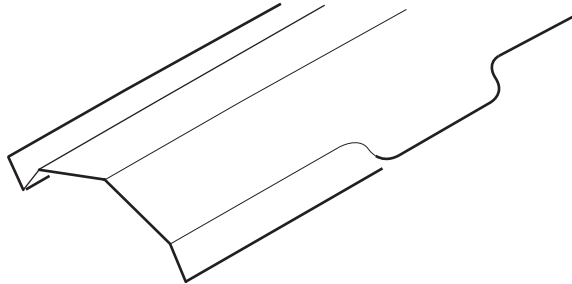

RR12_029

Stringline representation of a road design.

In RoadRunner such lines defining the design are called stringlines. Stringlines are the base elements used for stake out and check activities. Stringlines have a project unique name by which they are identified and selected. Whenever a new road design is typed in or imported from a design package these stringlines are generated automatically in the background.



A cross section may be derived from the stringline model by slicing the group of stringlines with a vertical plane orthogonal to the centre line.

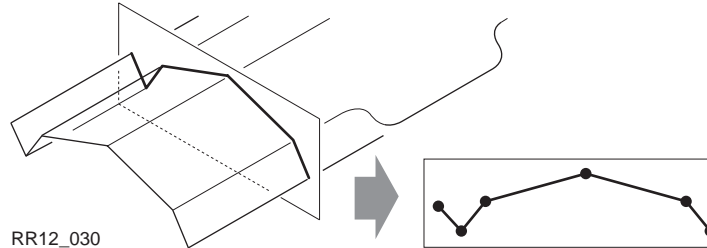

Vertical cut of a stringline group defines a cross section.

Layers

Roads generally consist of layers made of different materials, for example road surface of asphalt or concrete, layers of different gravel and so on. At different times throughout a project it may be required to work with different layers of the road. RoadRunner allows the possibility of creating such layers by grouping together sets of stringlines.

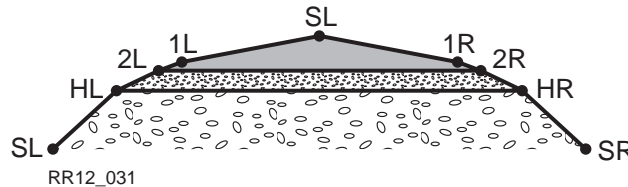

Example for a road with three different layers (general fill, gravel, final surface).

Type	Description
Layer one - general fill	Defined by the two hinge points HL, HR and the slope points SL, SR.
Layer two - gravel	Defined by the two hinge points HL, HR and 2L, 2R.

Type	Description
Layer three - final surface	Defined by the centre line CL and by 1L, 2L, 1R, 2R.



Stringlines are referenced by layers and can be used in more than one layer.



Every layer is relative to a centre line. This centre line does not have to be a part of the layer. In the previous example, layer one - general fill - uses the centre line for calculation even though the centre line is not part of the layer surface. Whereas the centre line is part of layer three - final surface.

8.3 Working with the Tasks (Advanced Mode)

Description

When staking out or checking a road, it is often the case that it is not possible to finish a particular task in one go. RoadRunner gives you the possibility of storing the element to be staked out or checked together with all defined settings as a work task. Tasks are stored as a part of the project.

Such tasks are also useful when working in a noisy and rough environment where it is not possible to reflect on whether a particular parameter should be used or not. In this case, you can define a task in the office and simply call-up the task in the field.

Every element defined for stake out or check, independent of whether it is a stringline, slope, X-slope, crown, layer or DTM, may be stored as a task. Tasks are created in the same way as elements are selected, during stake out or check. Refer to "4 Step 3 - Working in Advanced mode" for more information on creating tasks using the selection wizard.



Tasks use the basic elements of every road job: stringlines. Deleting or modifying a stringline used for a task automatically affects the task.



The seven last used tasks used on the project of each stake out/check type are remembered. For example the stake out method **Stringline** retains the last seven stringlines staked out/checked in this project.

8.4

Creating a New Road Job

Description

There are two ways of creating road jobs:

Typing them in manually by using the Alignment Tool Kit (ATK) program.

OR

Converting data created in a design package.

Manually entered data

Data can be typed in and edited with ATK or via RoadEd. Refer to "Alignment Tool Kit" and "RoadEd" for information on how to enter data manually.

Converted data

The Design to Field component of LGO offers converters from several road design and CAD packages. Several design packages also include a built in converter to RoadRunner. As different design packages follow different philosophies in representation, creation and storage of data the conversion process differs slightly.



RR12_065

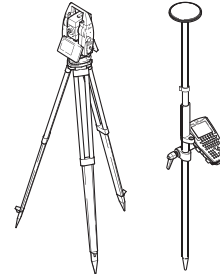

The LGO, LEICA Geo Office, can be found on the "System 1200 Office SW" CD.

The latest version of the Design to Field importers may be found in the downloads section of the Leica Geosystems website:

http://www.leica-geosystems.com/s-e/en/downloads/lgs_page_catalog.htm?cid=3291

8.5

Deleting an Existing Road Job

Accessing the screens

Highlight the desired job and press DEL (F4) on the RoadRunner Jobs screen.

Description

Road jobs, like measurement jobs, fixpoint jobs and DTM jobs, are only referenced by a project, this means that it is possible to use one job in more than one project. Deleting a road job deletes it from all projects that may reference it.

RR Road Jobs (Device)

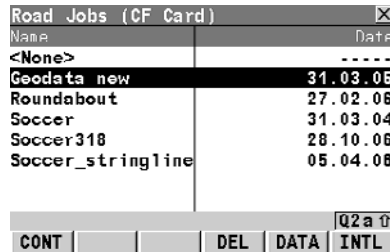

CONT (F1)

To select the highlighted road job and return to the previous screen.

DEL (F4)

To delete the highlighted road job.

DATA (F5)

To view/edit the data from the road job.

Refer to "9 Viewing and Editing the Design Data".

CFCRD (F6) or INTL (F6)

To switch between the CompactFlash card and the internal memory as the active device.

Delete road job step-by-step

Step	Description
1.	RR Road Jobs (Device). Highlight the road job to delete.
2.	Press DEL (F4) to delete the road job.

Next step

CONT (F1) to accept the changes and continue.

8.6 Working with a DTM Job

Accessing the screens

Highlight the DTM Job on the New Project or Edit Project, Jobs page and press ENTER.

Description

A DTM job (**D**igital **T**errain **M**odel) may consist of multiple DTM layers or surfaces. These DTM layers may cover either different locations, be on top of each other or even intersect each other. Refer to "11.3 Basic Elements for Road Stake and Check Measurements" for more information on DTM jobs in projects.

DTM jobs consist like road jobs of two major parts:

Type	Description
Design part	Contains all the information of the different triangle representing the various DTM layers.
Work task part	Defines how the DTM represented in the design part should be used in the field. For example which vertical shift should be added to the defined DTM surface. Tasks are stored as a part of the project.



DTM's are used in the RoadRunner check method DTM.

RR
DTM Jobs (Device)

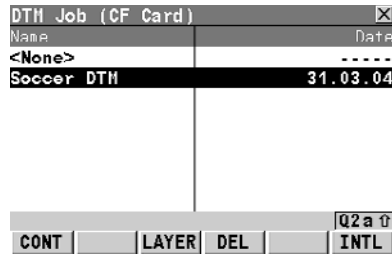

CONT (F1)

To select the highlighted DTM job and continue.

LAYER (F3)

To view the DTM layers of the highlighted DTM job.

DEL (F4)

To delete the highlighted DTM job.

CFCRD (F6) or INTL (F6)

To switch between the CompactFlash card and the internal memory as the active device.

9

Viewing and Editing the Design Data

9.1

Overview

Accessing the screens

Press DATA (F5) on the RoadRunner Setup screen or Road Jobs screen.

Viewing and Editing

The design data stored within the road job contains all of the information about the road design. This includes the stringlines and layers (for example, the geometry of the centre line or the layers of the different materials/surfaces which form the road). The design data can be viewed and partially edited in these View and Edit screens.

View&Edit Data	
Job Name :	Geodata new
Layer :	Layer 1
#Stringlines :	71
Centre line :	L42:1
Chainage :	1380.000
Ch Increment :	10.000
Q2 a	
CONT	EDIT VIEW

CONT (F1)

To return to the RoadRunner Setup screen.

EDIT (F3)

To edit the following design data:

- 1) to edit the general job details,
- 2) to select another centre line and include/exclude stringlines from the selected layer,
- 3) to change the start chainage of the centre line of the selected layer.

VIEW (F4)

To view the following design data in a selected layer:

- 1) to view specific details of the layer centre line,
- 2) to view the list of all stringlines in the layer,
- 3) to view cross-section plots.

Field	Description of field
Job Name	The name of the active road job, as defined in the project.
Layer	To select a layer from the active road job. All of the layers within the active road job can be selected.
#Stringlines	The number of stringlines from the selected layer.
Centre line	The name of the layer centre line.
Chainage	To enter a start chainage to use when viewing the data. The default value is the start chainage of the layer centre line.
Ch Increment	To enter a chainage increment to use when stepping through the data
	If a centre line has not been defined, a start chainage cannot be entered and the field will be shown as "----". If a centre line has not been defined, a chainage increment cannot be entered and the field will be shown as "----".

9.2 Viewing the Design Data

Accessing the screens

Press VIEW (F4) on the RoadRunner View&Edit Data screen.

Viewing details of the layer centre line

This page shows the following:

Geometrical details of the selected stringline at the selected chainage.

View at 1410.000	
Line Infn	Lines Plnt
Line name	: L42:1
Easting	: 3505233.539 m
Northing	: 5372194.715 m
Height	: 346.475 m
Hz Tangent	: 187.2854 g
Hz Radius	: ----- m
Hz Type	: Multipoint
Hz Offset	: 0.000 m
Q2 a 0	
CONT	CH+
CH-	SEG
HZ/VT	PAGE

CONT (F1)

To return to the View&Edit Data screen.

CH+ (F2)

To increase the chainage by the chainage increment, as defined in the View&Edit Data screen.

CH- (F3)

To decrease the chainage by the chainage increment, as defined in the View&Edit Data screen.

SEG (F4)

To enter the Segment Info screen.

HZ/VT (F5)

To toggle between the vertical alignment data and the horizontal alignment data.

PAGE (F6)

To move to the next page.

SHIFT INIT (F5)

To force a re-calculation of all values.

Field	Description of field
Line name	To select a stringline from the layer.
Easting	The East coordinate of the stringline.
Northing	The North coordinate of the stringline..

Field	Description of field
Height	The height of the stringline.
The following fields/values can be toggled, by using the HZ/VT (F5) softkey:	
Hz Tangent/Grade	The tangent direction or grade of the stringline.
Hz/Vt Radius	The horizontal/vertical radius of the stringline segment.
Hz/Vt Type	The horizontal/vertical segment type.
Hz/Vt Offset	The horizontal/vertical offset to the layer centre line.
 If a value has not been defined, the field will be shown as "----".	

Viewing a list of all stringlines in the layer

This page shows the following:

A list of all stringlines in the current layer, their centre line offsets and height differences or absolute heights at the selected chainage.

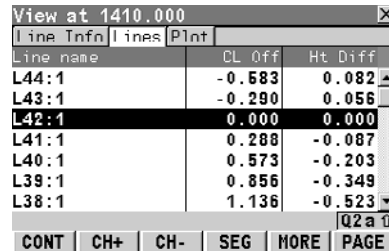

Line name	CL Off	Ht Diff
L44:1	-0.583	0.082
L43:1	-0.290	0.056
L42:1	0.000	0.000
L41:1	0.288	-0.087
L40:1	0.573	-0.203
L39:1	0.856	-0.349
L38:1	1.136	-0.523

CONT (F1)

To return to the View&Edit Data screen.

CH+ (F2)

To increase the chainage by the chainage increment, as defined in the View&Edit Data screen.

CH- (F3)

To decrease the chainage by the chainage increment, as defined in the View&Edit Data screen.

SEG (F4)

To enter the Segment Info screen.

MORE (F5)

To toggle between the height differences or absolute heights at the selected chainage.

PAGE (F6)

To move to the next page.

SHIFT HOME (F2)

To move to the start of the list of stringlines.

SHIFT END (F3)

To move to the end of the list of stringlines.

SHIFT INIT (F5)

To force a re-calculation of all values.

Column	Description of column
Line Name	The name of the stringline in the selected layer.
CL off	The offset of the stringline from the layer centre line.
The following columns/values can be toggled, by using the MORE (F5) softkey:	
Ht Diff	The height difference of the stringline to the layer centre line.
Height	The absolute height of the stringline.

Viewing cross sections**This page shows the following:**

A cross section view of the design data at the selected chainage and the name of the selected stringline. Only stringlines with height information are shown. The displayed arrow points at the centre line or at the stringline which was last selected. No selection or zoom/pan functionality is available.



Viewing the segment: the Hz Alignment page

This page shows the following:

Detailed horizontal alignment information about the current stringline segment.

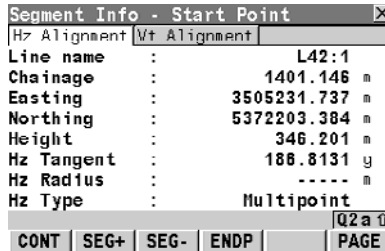

CONT (F1)

To return to the View&Edit Data screen.

CH+ (F2)

To increase the chainage by the chainage increment, as defined in the View&Edit Data screen.

CH- (F3)

To decrease the chainage by the chainage increment, as defined in the View&Edit Data screen.

SEG (F4)

To enter the Segment Info screen.

PAGE (F6)

To move to the next page.

SHIFT INIT (F5)

To force a re-calculation of all values.

CONT (F1)

To return to the View screens.

SEG+ (F2)

To move to the next segment.

SEG- (F3)

To move to the previous segment.

ENDP/STRTP (F4)

To toggle between the start point and the end point of the segment.

PAGE (F6)

To move to the next page.

Field	Description of field
Line Name	The name of the selected stringline.
The following fields/values can be toggled, by using the ENDP/STRTP (F4) softkey:	
Chainage	The chainage of start/end point of the segment.
Easting	The East coordinate of the start/end point of the segment.
Northing	The North coordinate of the start/end point of the segment.
Height	The height of the start/end point of the segment.
Hz Tangent	The tangent direction at the start/end point of the segment.
Hz Radius	The radius at the start/end point of the segment (is not toggled).
Hz Type	The current segment type (is not toggled).
 If a value has not been defined, the field will be shown as "----".	

Viewing the segment: the Vz Alignment page

This page shows the following:

Detailed vertical alignment information about the current stringline segment.

Segment Info - Start Point	
Hz Alignment	Vt Alignment
Line name	: L42:1
Chainage	: 1401.146 m
Easting	: 3505231.737 m
Northing	: 5372203.384 m
Height	: 346.201 m
Grade	: 32.342:1 hv
Vt Radius	: ---- m
Vt Type	: Straight
Q2 a ↑	
CONT	SEG+
SEG-	ENDP
PAGE	

CONT (F1)

To return to the View screens.

SEG+ (F2)

To move to the next segment.

SEG- (F3)

To move to the previous segment.

ENDP/STRTP (F4)

To toggle between the start point and the end point of the segment.

PAGE (F6)

To move to the next page.

Field	Description of field
Line Name	The name of the selected stringline.
The following fields/values can be toggled, by using the ENDP/STRTP (F4) softkey:	
Chainage	The chainage of start/end point of the segment.
Easting	The East coordinate of the start/end point of the segment.
Northing	The North coordinate of the start/end point of the segment.
Height	The height of the start/end point of the segment.
Grade	The grade at the start/end poin of the segment (is not toggled).
Vt Radius	The radius at the start/end point of the segment (is not toggled).
Vt Type	The current segment type (is not toggled).
	If a value has not been defined, the field will be shown as "----".

9.3 Editing the Design Data

Accessing the screens

Press EDIT (F3) on the RoadRunner View&Edit Data screen.

Editing the job details

```

Edit: Geodata new
---|Layer|Centraline
Name       : Geodata new
Description : ~REB Transforma
           : -----
Creator    : hgei
Device     : CF Card
  
```

Q2 a 0

STORE PAGE

STORE (F1)

To return to the View&Edit Data screen.

PAGE (F6)

To move to the next page.

Field	Description of field
Name	The unique name of the road job. The name may be up to 16 characters long and may include spaces. This field is mandatory.
Description	A detailed description of the road job (two lines are available). This field is optional.
Creator	The name of the person who created the road job. This field is optional.
Device	CF Card or Internal Memory. The device on which the road job is stored.

Selecting another centre line and including/excluding stringlines from the selected layer

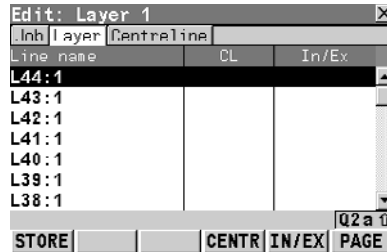

STORE (F1)

To store data and return to the View&Edit Data screen.

CENTR (F4)

To set the highlighted stringline as the layer centre line.

IN/EX (F5)

To include/exclude the highlighted stringline from the layer.

PAGE (F6)

To move to the next page.

Column	Description of column
Line Name	The column showing the names of the stringlines
CL	The column showing the stringline which is set as the layer centre line
In/Ex	The column showing which stringlines are excluded from the layer

Changing the start chainage of the centre line of the selected layer

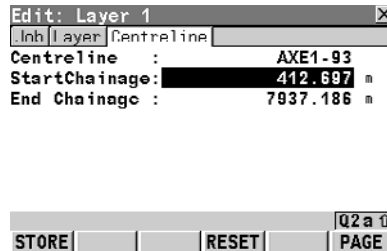

STORE (F1)

To store data and return to the View&Edit Data screen.

RESET (F4)

To clear all changes made to the start chainage reset to the original start chainage.

PAGE (F6)

To move to the next page.

Field	Description of field
Centreline	The name of the centre line.

Field	Description of field
StartChainage	To enter a start chainage for the layer centre line. By using the centre line length, the end chainage is automatically calculated.
End Chainage	The end chainage of the layer centre line, as calculated from the start chainage.

10**Working with the Extras Menu**

10.1**Overview**

Accessing the screens

Press SHIFT EXTRA (F5) on any page of the measurement screen

Description

- This menu contains additional functionality for each of the stake and check methods. This functionality is additional to those already existing functions which are available via the function keys.
 - The functionality differs between the stake and check methods.
-

10.2

Common Extras - Manual/DTM Height

Description

- RoadRunner offers the possibility to switch to either:
 - a height which is entered manually by the user,
This option enables the manual definition of a height, which can be applied for staking out or checking.
 - a height which is retrieved from an existing DTM Layer, as defined in the DTM job.
This option enables a layer from a DTM, associated with the project, to be applied and used as a height reference for the staking out or checking of alignments that only exist in 2D format.
- Once defined, this menu function remains active until it is turned off by either applying the menu function **Reset Height to Design** or by stepping out of the task.

Availability

- This menu function is available to all stake and check methods.

RR Manual/DTM Height

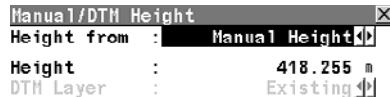

CONT (F1)

To start the highlighted extras item

Description of fields

Field	Option	Description
Height from	Manual Height	To define a height manually. The height is then typed in under Manual Height .
	DTM Layer	To define a layer from a DTM job which is associated with the project. The DTM layer is then selected under DTM Layer .
Height	User input	Manual height of the point to stake out or check.
DTM Layer	User input	Layer of the DTM job to be used as a height reference.

10.3

Common Extras - 2nd Height from DTM

Description

- RoadRunner offers the possibility to retrieve heights from a second existing DTM Layer, as defined in the DTM job.
- Three new information lines are added to the Info page. These information lines are **DTM 2 Ht Diff**, **DTM 2 Height** and **DTM 2 Name**.
- The current triangle of the DTM is shown on the Plot page. This is available when choosing **Plot Type: Cross-Section**. Refer to "Graphical display of current DTM element in cross-section plot" for more information.

Availability

This menu function is available to the following stake and check methods:

- Stringline, Individual Stringline, X-Slope, Crown, Layer.

RR DTM Height



Description of fields

Field	Option	Description
DTM Layer	User input	Second Layer of the DTM job to be used as a height reference.

Graphical display of current DTM element in cross-section plot

When selecting a second DTM layer the relevant triangle of the DTM is shown on the **Plot** page. The information lines **DTM 2 Ht Diff**, **DTM 2 Height** and **DTM 2 Name** are automatically added to the end of the **Info** page.

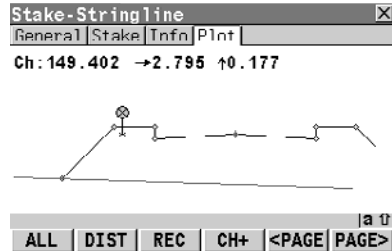

10.4

Common Extras - Shift Reference Line

Description

- When staking-out or checking different layers of the road strata, such as the sub-grade, gravel or asphalt, it is often found that not all of these layers are available in the design. For such cases RoadRunner offers the possibility to apply either a negative or positive height shift to the design values.

Availability

This menu function is available to the following stake and check methods:

- Slope, X-Slope.

The **Shift Reference Line** item of the EXTRA menu stays disabled until the first measured position is available. The current chainage **Chainage** is used for the cross-section shown to pick the reference line.

Example

In this example a gravel layer with a thickness of 10cm should be staked-out. Therefore a negative vertical shift to the final design surface is applied. This shift is applied in the Selection Wizard by adding a vertical shift of -10cm. As shown below the selected X-Slope is shifted by 10cm.

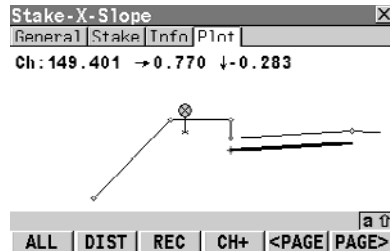

When staking-out the newly shifted X-Slope, the original left edge of the shifted X-Slope is of little interest and it is the intersection with the left end slope that is of greater interest.

Screen

```

Reference Shift
Ref Surface : [Slide Bar]
Left Line  : Left Hinge
Right Line : Right Hinge

Shift Mode : Perpendicular
Shift Value : 0.0000 m

CONT CLEAR SELECT
  
```

To apply these particular changes, the reference line for the X-Slope can be shifted using the **Shift Reference Line** menu function. Select the **Ref Surface** either via the slide-bar or by using the graphical selection by using **SELCT (F4)**. The required element for the reference shift is then confirmed with **CONT (F1)**.

Description of fields

Field	Option	Description
Ref Surface	Slide bar	
Left Line	output	Shows the name of the left stringline from the with sidebar selected surface.
Right Line	output	Shows the name of the right stringline from the with sidebar selected surface.
Shift Mode	Choicelist	The vertical shift applied to the surface selected via the sidebar.
	Plumbline	The shift defined under Shift Value gets applied following the plumbline.

Field	Option	Description
	Perpendicular	The shift defined under Shift Value gets applied perpendicular to the selected surface Ref Surface .
Shift Value	Input	Value the selected surface Ref Surface gets shifted following the chosen Shift Mode .



The graphical selection is identical to the workflow used in the Selection Wizard, with the original element highlighted in grey.

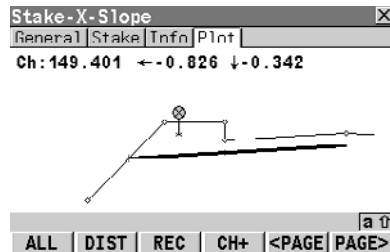

The expanded element and the shifted reference line, marked with a cross, are shown in the Plot page. The **ΔOffset** and **ΔHeight** values displayed on the Stake page guide you to the new shifted position.

In **RR Reference Shift** a shift for the reference surface can also be applied by using **Shift Value**. This value can either be perpendicular to the reference surface or along the plumb-line, depending on the selected **Shift Mode**.

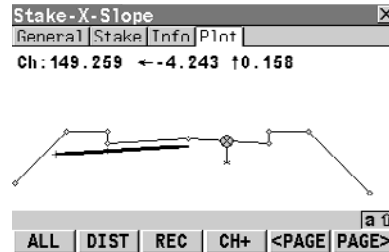

The screen shows the previous X-Slope, with the 10cm gravel layer and the reference surface shifted by 15cm by applying with Shift Mode: Plumbline a Shift Value: 0.150m on the **RR Reference Shift** screen.

Graphic

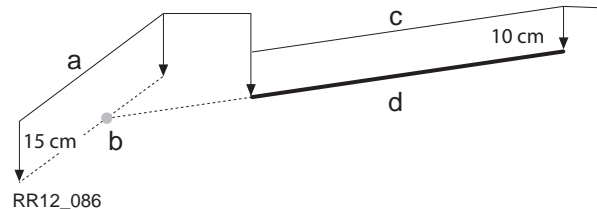

- a) Reference Surface
- b) Shifted Reference Point
- c) Original X-Slope
- d) Shifted X-Slope

10.5

Common Extras - Reinitialise Search

Description

When staking or checking complex road designs it can happen that the actual position is not projected to the desired segment of the alignment. The Reinitialise Search forces a re-projection of the actual position.

Availability

This menu function is available to the following stake and check methods:

- Stringline, Indiv Stringline, X-Slope, Manual Slope, Slope, Layer and Crown.

Example

Before initialisation

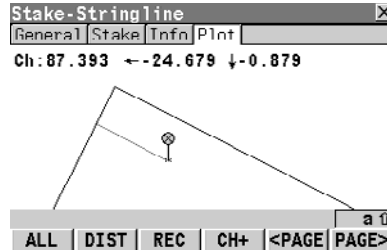

This screen shows the projection of the actual position to the left segment, although the distance to the right segment is shorter.

After initialisation

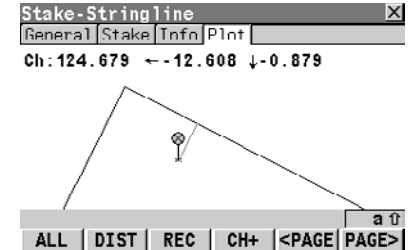

This screen shows the projection after the reinitialisation.

10.6

Extras for Stringline

Description

The extra functionality for the staking and checking of Stringlines is similar to the extra functionality for X-Slope, Layer and Crown.

Extras Menu

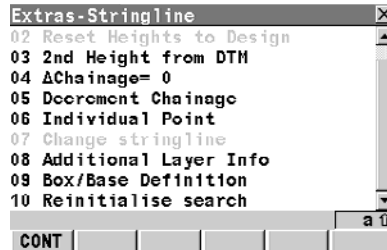



CONT (F1)

To start the highlighted extras item

Description of menu functions

Menu function	Description
Manual/DTM Height	Refer to "10.2 Common Extras - Manual/DTM Height".
Reset Height to Design	To deactivate a manually defined height and return to the height defined in the design.  Reset Height to Design indicates whether manual heights are being used as it is only enabled when a manual height is active.
2nd Height from DTM	Refer to "10.3 Common Extras - 2nd Height from DTM".

Menu function	Description
ΔChainage = 0	<p>To set def Chainage on the General page of the stake out to the current Chainage.</p> <p> This extra functionality is only available for stake out methods.</p>
Decrement Chainage	<p>To decrement the def Chainage on the General page of the stake out by the Ch Increment.</p>
Individual Point	<p>To access RR Data: Fixpoint job name which allows you to stake out points with known Easting, Northing and Height. Points can either be selected from the fixpoint job or manually typed in. The def Chainage and Stake Offset on the General page of the stake out are calculated based on the coordinates of the selected point. The height for the stake out will be set as Manual Height.</p> <p> If the chosen point has no height the design height will be used. If the point has a height it is possible to use that one or continue working with the design height.</p>
Change stringline	<p>To access RR Selection Wizard-Select which allows you to chose a different stringline for the stake-out. This change is only temporary and will not effect the task.</p>

Menu function	Description
Additional Layer Info	<p>This function allows additional road data to be obtained during a check or stake survey of a road element.</p> <p>It is no longer required to change the layer or stringline in Standard Mode or to change to a different task in Advanced Mode.</p> <p>Road elements include centre lines, kerb and gutters and slopes.</p>
Box/Base Definition	<p>This function allows a box or similar structure to be set out (related to a stringline chainage and parallel offset) during a check or stake survey of a road element.</p> <p>A base point of the box, user defined dimensions of the box (a base distance and a base offset) are required.</p>

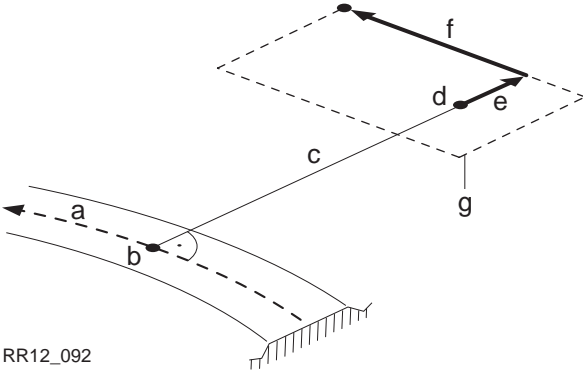
Menu function	Description
	<p>Road elements include centre lines, kerb and gutters and slopes.</p>  <p>RR12_092</p> <ul style="list-style-type: none"> a) Centre line b) Defined chainage c) Stake offset d) Base point e) Base offset f) Base distance g) Box to stake out

Additional Layer Info

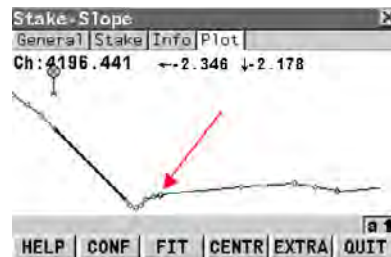

1 Press SHIFT EXTRA (F5) to access Extras menu.

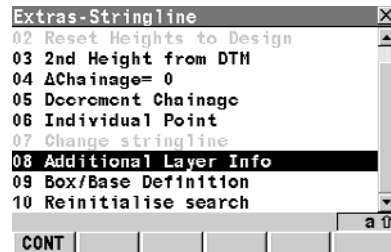

2 Select Additional Layer Info.

Press CONT (F1) to continue to the next screen.

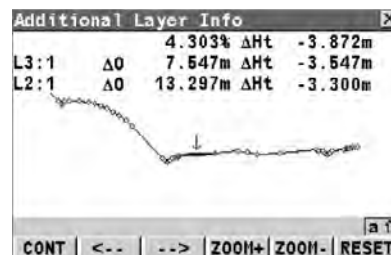

3 Press <-- (F2) and --> (F3) to select the relevant element in the plot. The information displayed shows the current slope ratio of the element, the height difference and the offset and height difference from the left and right vertices of the element.

Press CONT (F1) to store the selected element, which is then automatically recalled.

Press RESET (F6) to move back to the originally selected element.

Box/Base Definition

The following steps describe the stake out of two reference pegs from a centre line chainage and offset.

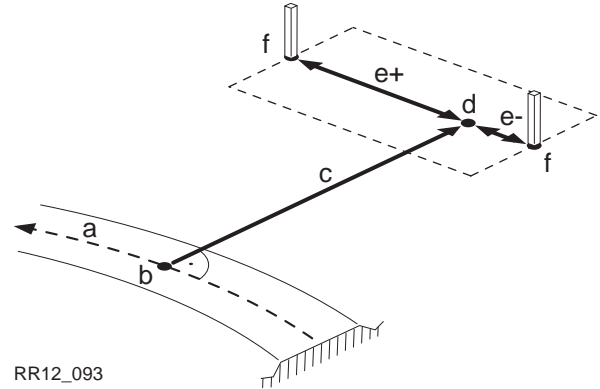

RR12_093

- a) Centre line
- b) Defined chainage
- c) Stake offset
- d) Base point
- e) Base distance, positive (e+), negative (e-)
- f) Peg to stake out

Stake-Indv Stringline	
General	Stake
Point ID :	100
Reflector Ht :	1.300 m
Def Chainage :	32.399 m
Ch Increment :	0.000 m
Stake Offset :	5.000 m
Stake Ht Diff:	0.000 m

Q2 a ↑

ALL | DIST | REC | CH+ | <PAGE | PAGE>

- 1 Define the base point for the box/base stake-out using Stake Offset and Stake Ht Diff from the General page.

Press SHIFT EXTRA (F5) to access Extras menu.

Extras-Stringline	
02	Reset Heights to Design
03	2nd Height from DTM
04	ΔChainage= 0
05	Decrement Chainage
06	Individual Point
07	Change stringline
08	Additional Layer Info
09	Box/Base Definition
10	Reinitialise search

a ↑

CONT | | | | | |

- 2 Select Box/Base Definition.

Press CONT (F1) to continue to the next screen.

Box/Base Definition	
Base Chainage:	200.000 m
Base Offset :	5.000 m
Dist Box :	-2.000 m
Offset Box :	1.000 m
Base Easting :	-19829.373 m
Base Northing:	5301112.169 m
Base Height :	416.643 m
Base Direct'n:	109.4677 g

Q2 a ↑

CONT | DEF'N | BASE | | | |

- 3 The position defined by Def Chainage and Stake Offset is used as Base Chainage and Base Offset when accessing Box/Base Definition for the first time within a stake-out session.

-
- 4 Similar to the stake-out of individual points in the Extras menu, the Box/Base functionality calculates the new point to stake-out and changes the according values of Def Chainage, Stake Offset and activates the Manual Height functionality.

To avoid that these values are used as the next base point when accessing the box/base menu press BASE (F3) in the Box/Base Definition panel to freeze the values of the base point. BASE (F3) is now replaced by CLEAR (F3). If a different base had been defined before, use DEF'N (F2) to overwrite the values before pressing BASE (F3).

-
- 5 Define the Base Distance and Base Offset in the Box/Base definition panel. Base Distance and Base Offset follow the same rules as used for the definition of offsets and chainages in general, (offset to the right = positive; distance in direction of increasing chainage = positive).

Press CONT (F1) to continue to the next screen.

Stake-Indv Stringline	
General	Stake
Point ID :	100
Reflector Ht :	1.300 m
Def Chainage :	32.000 m
Ch Increment :	0.000 m
Stake Offset :	5.049 m
Stake Ht Diff:	0.000 m

- 6 The values of Def Chainage, Stake Offset and the Manual Height are adjusted accordingly.

Stake-Indv Stringline	
General	Stake
Ch :	118.049 m
CL 0:	5.990 m
Δ Ch :->	0.1013 g
Δ Off:↓	-0.038 m
Δ Ht :↑	0.051 m
NrTP:	14.845 m

- 7 The fields Δ Chainage, Δ Offset and Δ Height on the Stake page guide you to the new position to stake-out.

Press SHIFT EXTRA (F5) to access Extras menu.

Stake-Indv Stringline	
General	Stake
Ch :	118.049 m
CL 0:	5.990 m
Δ Ch :->	0.1013 g
Δ Off:↓	-0.038 m
Δ Ht :↑	0.051 m
NrTP:	14.845 m



- 8 Select Box/Base Definition.

Press CONT (F1) to continue to the next screen.

Extras-Stringline	
02 Reset Heights to Design	
03 2nd Height from DTM	
04 Δ Chainage= 0	
05 Decrement Chainage	
06 Individual Point	
07 Change stringline	
08 Additional Layer Info	
09 Box/Base Definition	
10 Reinitialise search	

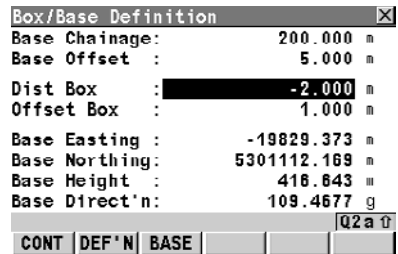

9 The next point of the box to stake-out can now be defined.

To change back to the original chainage and offset defined for the base point definition use CLEAR (F3) from the Box/Base Definition panel.

10 Start with step 1 to define a new box/base.

10.7

Extras for X-Slope, Layer and Crown

Description

The extra functionality for the staking and checking of X-Slope, Layer and Crown is similar to the extra functionality for Stringlines.

Extras Menu

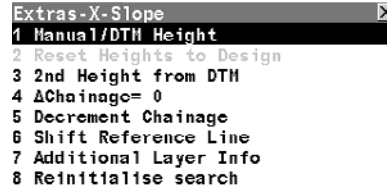

CONT (F1)

To start the highlighted extras item

Description of menu functions

Menu function	Description
Manual/DTM Height	Refer to "10.2 Common Extras - Manual/DTM Height".
Reset Height to Design	To deactivate a manually defined height and return to the height defined in the design.  Reset Height to Design indicates whether manual heights are being used as it is only enabled when a manual height is active.
2nd Height from DTM	Refer to "10.3 Common Extras - 2nd Height from DTM".

Menu function	Description
ΔChainage = 0	<p>To set def Chainage on the General page of the stake out to the current Chainage.</p> <p> This extra functionality is only available for stake out methods.</p>
Decrement Chainage	To decrement the def Chainage on the General page of the stake out by the Ch Increment .
Shift Reference Line	Refer to "10.4 Common Extras - Shift Reference Line".
Additional Layer Info	Refer to "10.6 Extras for Stringline" for details.

10.8

Extras for Slope

Description

The extra functionality for the staking and checking of Slopes is similar to the extra functionality for manually defined slopes and design slopes. Depending on the **Slope Method** chosen in **RR Road Configuration**, the menu items may vary. Differences are pointed out in the table below.

Extras Menu

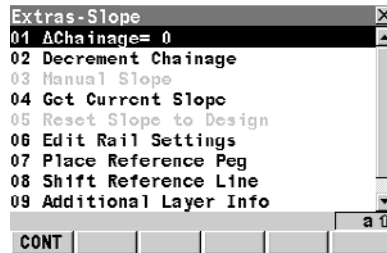



CONT (F1)

To start the highlighted extras item

Description of menu functions

Menu function	Description
ΔChainage = 0	To set def Chainage on the General page to the current Chainage .  This extra functionality is only available for stake out methods.
Decrement Chainage	To decrement the def Chainage on the General page of the stake out by the Ch Increment .

Menu function	Description
Manual Slope	<p>To access RR Slope Definition which allows a manual slope to be defined. The defined manual slope is then used for all points to stake out or check.</p> <p> The manual slope is active until it is turned off with Reset Slope to Design from Extras.</p>
Get Current Slope	<p>To access RR Slope Definition. The slope ratio Current Ratio of the last measured position is used as the defined Slope Ratio. All others values in RR Slope Definition are filled in with the last measured position. The defined manual slope is used for all points to stake out or check.</p> <p> The manual slope is active until it is turned off with Reset Slope to Design from Extras.</p>
Reset Slope to Design	<p>To deactivate a manually defined slope and return to the slope defined in the design.</p> <p> Reset Slope to Design can be used as an indicator if working with an manual slopes, as it is only enabled if a manual slope is active.</p>
Shift Reference Line	<p>Refer to "10.4 Common Extras - Shift Reference Line".</p>
Additional Layer Info	<p>Refer to "10.6 Extras for Stringline" for details.</p>

Defining slopes manually

Description

Slopes are defined relative to the centre line.

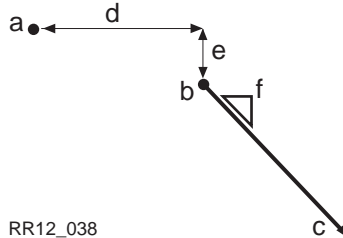

RR12_038

- a) Centre line
- b) Hinge point
- c) New slope
- d) **def Hng Off**
- e) **def Hng HtD**
- f) **Slope Ratio**

Screen

Slope Definition	
Ref Line :	TUTORIAL
Hinge Type :	Relative
def Hng Off :	3.5000 m
def Hng HtD :	0.1500 m
Slope Type :	Cut Right
Slope Ratio :	2:1 hv
a ↑	
CONT	CONF

CONT (F1)

To accept changes and move to the next screen depending on the settings for slope staking.

CONF (F2)

To configure the RoadRunner application program. Accesses **RR Configuration**.

Description of fields

Field	Option	Description
Ref Line	Output	The centre line the slope is defined relative to.
Hinge Type	Choicelist Relative	The vertical offset type for the hinge point. Define the hinge point by the height difference relative to the selected reference line Ref Line .

Field	Option	Description
	<p>Absolute</p> <p>Define the hinge point using its absolute height.</p> <p>Relative: Absolute:</p> <p>RR12_039</p> <p>Hold Hinge</p> <p>The hinge point of the slope stays fixed at the defined stringline.</p>	
def Hng Off	User input	The horizontal offset of the hinge point from the centre line/reference line.
def Hng HtD	User input	The height difference of the hinge point from the centre line/reference line. This field is visible if Hinge Type: Relative .
def Hng Elev	User input	The absolute height of the hinge point. This field is visible if Hinge Type: Absolute .

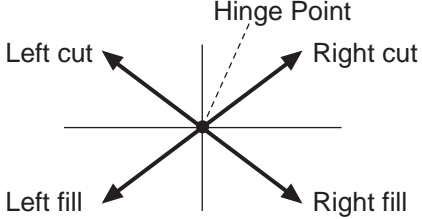
Field	Option	Description
Slope Type	Choicelist	<p>Differentiates if the defined slope is a cut/fill and left/right.</p>  <p>The diagram shows a central point labeled 'Hinge Point' with a dashed line pointing to it from above. Four arrows radiate from this point: one pointing up-left labeled 'Left cut', one pointing up-right labeled 'Right cut', one pointing down-left labeled 'Left fill', and one pointing down-right labeled 'Right fill'. A horizontal line and a vertical line intersect at the hinge point.</p> <p>RR12_079</p>
Slope Ratio	User input	<p>Defines the ratio of the slope.</p> <p>The format of Slope Ratio depends on the settings chosen in RR Project Configuration for Slope Format.</p>

11**Understanding Stake and Check Basics**

11.1**Overview**

General

In order to make the chapters on staking and checking road alignments easier to understand, the basics are introduced in this chapter.

Please be aware that the terminology or workflow used on different construction sites may vary from the one used in this manual, however, basic principles remain the same.

11.2

Basic Terms

Technical terms

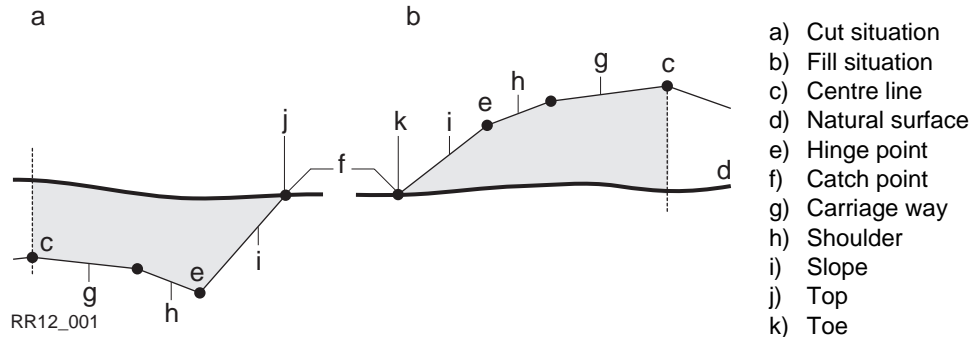

Technical term	Description
Carriage way	The part of the road on which you drive once the road is finished.
Shoulder or Verge	Often located next to the carriage way, usually with a slightly higher slope ratio than the carriage way.
Slope	Located next to the verge and can be thought of as linking the road level with the natural surface. The ratio of the slope is greater than the ratio of the verge. A slope starts at the hinge point .
Natural surface or original ground	This is the undisturbed surface before project construction.

Technical term	Description
Finished road level	Describes the final road surface.
Catch point or daylight point	Indicates the point of intersection between the slope and the natural surface. Both the hinge point and the catch point lie on the slope. In the case of a cut slope, the catch point forms part of the top of a bank (top). In the case of a fill slope, the catch point forms part of the bottom of a bank (toe).
Chainage or station	The cumulative distance along the centre line, frequently but not always starting at zero.

11.3

Basic Elements for Road Stake and Check Measurements

Description

In general there are four different basic stake out and check elements:

- Stringlines, for example, a centre line.
- Cross slopes or X-slopes, for example, the final carriage way.
- Slopes, for example, the end-slopes of a cross section.
- Surfaces, for example, a DTM surface.

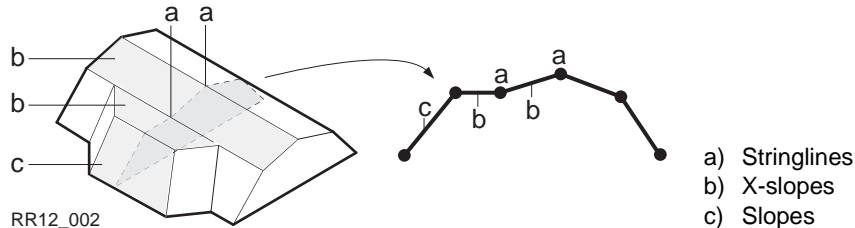

Every stake out or check is based on one or more of these four base elements. For example, a road crown consists of two X-slopes with one common stringline.

Stringlines

The stake out of a stringline is used in different situations:

- Centre line of a road.
- Edges of a road or any other change in slope.
- Gutters.
- Pipelines, cables and any other alignment related design feature.

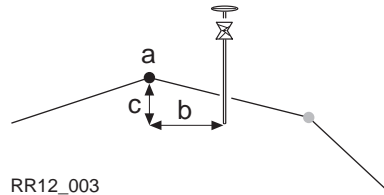

RR12_003

- a) Stringline to stake out or check, in this case the centre line
- b) Stringline offset **Strgl Offset**
- c) Stringline height difference **Strgl Ht Diff**

X-slopes

X-Slopes are defined by two stringlines. The two stringlines define the right and left edge of the X-slope. One of the two stringlines is used as the reference line.

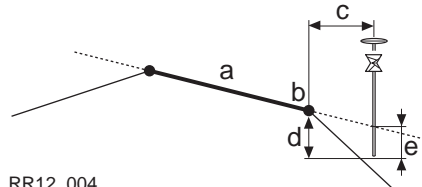

RR12_004

- a) X-slope to stake out or check
- b) Reference line
- c) Horizontal offset to reference line **Ref Offset**
- d) Height difference to reference line **Ref Ht Diff**
- e) Height difference to expanded X-slope **X-Slp Ht Diff**

Slopes

Slopes, like X-slopes, are defined by two stringlines. Different to X-slope only one edge of the slope, the hinge point, is known. The second edge, catch point or daylight point, is defined by the intersection of the slope and the natural surface. As the natural surface is unknown this edge can only be staked out in the field. To find and stake out the catch point is the most important task if working with slopes.

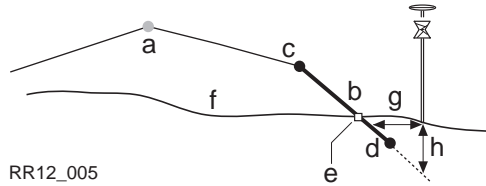

RR12_005

- a) Centre line
- b) Slope
- c) Hinge Point
- d) Second stringline defining the slope
- e) Catch point
- f) Natural surface
- g) Δ Offset from the slope
- h) Height difference Δ Height from the slope

Surfaces

There are two types of surfaces supported that represent a three dimensional design:

- DTM / TIN (**D**igital **T**errain **M**odel; **T**riangular **I**rrregular **N**etwork).
- Layer.

A DTM consists of a number of 3D triangles. DTM's do not include information relating the DTM to a centre line. Positions are defined by easting, northing and height value.

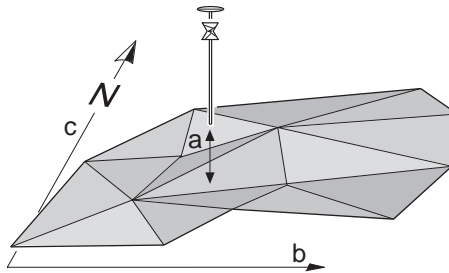

RR12_006

- a) Height difference **DTM Ht Diff** from the triangle of the DTM found in the same vertical as the measured point
- b) Easting of coordinate system
- c) Northing of the coordinate system

A layer is a combination of stringlines that form a 3D surface relative to a centre line. Thus it is possible to define points by chainage or station, offset and height. Refer to "8.2 Working with the Design Data (Stringlines and Layers)" for more information.

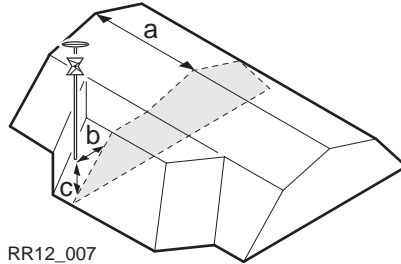

RR12_007

- a) Chainage or station
- b) Layer Offset**
- c) Layer height difference **Layer Ht Diff**

11.4

Shifts

11.4.1

Overview

Description

When working on site, it is often the case that design data does not match the measured data. For example, an existing road surface that should intersect with the design surface may be 15 cm higher than the plans indicate. To guarantee a smooth intersection, this difference has to be distributed over the remaining 100 m of paving. To handle these situations, Road-Runner allows the possibility of adding shifts to the existing design data. A shift is applied when selecting the element to stake out/check.



Note that shifts do not change the stored design. They are applied temporarily for stake out purpose.

Horizontal and vertical shifts

Horizontal shifts are always rectangular to the centre line of the element you are working with. Whereas vertical shifts defined along the plumb line.

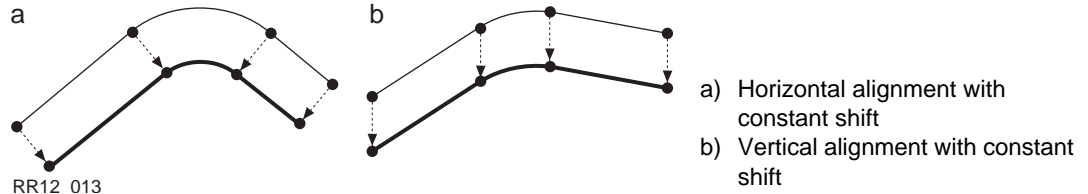

Constant, linear and parabolic shifts

Three different types of shifts are supported:

Type	Description
Constant	The shift stays the same from its start chainage or station to the end chainage or station.
Linear	The shift is linear interpolated along the chainage or station.
Parabolic	A parabolic shift is added between start and end chainage or station.

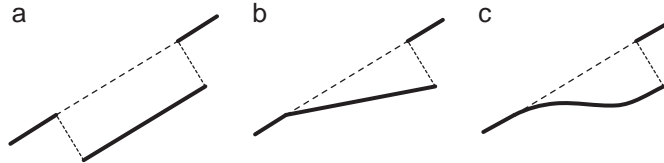

RR12_014

- a) Constant shift
- b) Linear shift
- c) Parabolic shift and reverse curve

Sign convention for shifts

The sign convention for design shifts is identical to the one used for stake offset and height difference.

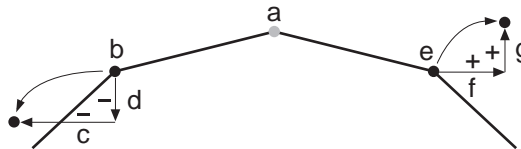

RR12_053

- a) Centre line
- b) Stringline on left side
- c) Negative horizontal shift
- d) Negative vertical shift
- e) Stringline on right side
- f) Positive horizontal shift
- g) Positive vertical shift



Horizontal stake offsets are always defined perpendicular to the centre line of the layer the stringline(s) belongs to.

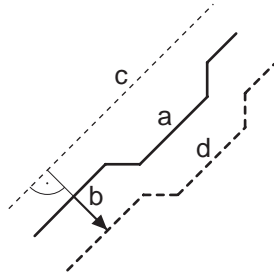

RR12_010

- a) Stringline the horizontal shift is applied to
- b) User defined horizontal shift for the stringline
- c) Centre line
- d) Shifted stringline

Plot page with shifts

RoadRunner offers for all stake out and check methods a page showing a graphical representation of the measured position in relation to the cross section. If shifts are applied to the design the plot shows the original unshifted cross section view of the design as well as the shifted element. The current element is shown in bold.

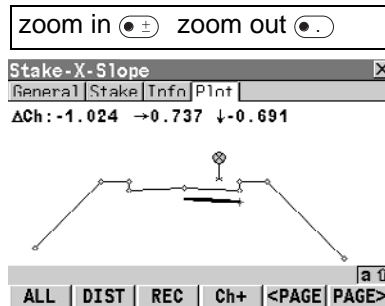

The original cross section of the design is shown as well as the shifted element in bold.

11.4.2

Shifts for Stringlines, Slopes, Layers and DTM's

Description

The shifts applied to stringlines, slopes, road crowns layers and DTM's are identical with one exception:

- Given that DTM's are not defined relative to a centre line and hold no orientation information, no horizontal shift is possible for them.

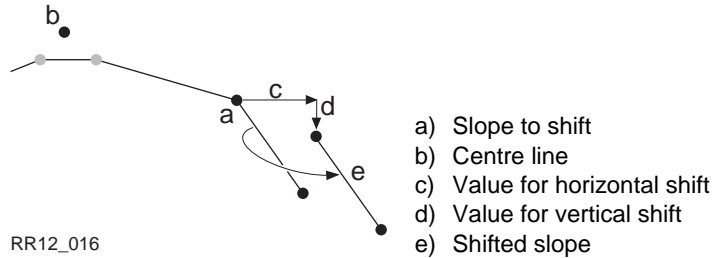

11.4.3

Shift for X-Slopes and Road Crowns

Description

To allow widening and narrowing of X-slopes and road crowns, only one of the two stringlines defining the X-slope or crown is shifted when adding a horizontal shift. This is handy for small changes to the original design like for bus stops or emergency bays.

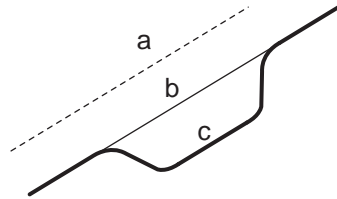

RR12_017

- a) Centre line
- b) Original stringline of the design
- c) Stringline with horizontal parabolic shift

Horizontal shift

For X-slopes and crowns the horizontal shift is added to the stringline that is defined as reference line. To maintain the original X-slope/crown ratio the stringline is shifted along the X-slope/crown.

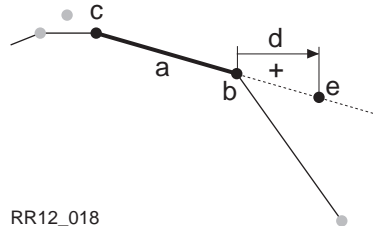

RR12_018

- a) X-Slope to shift
- b) Reference stringline of the X-slope
- c) Second stringline of the X-slope
- d) Positive horizontal shift
- e) Position of the shifted reference stringline

Vertical shift

The vertical component of the shift for a X-slope or crown is applied to all stringlines.

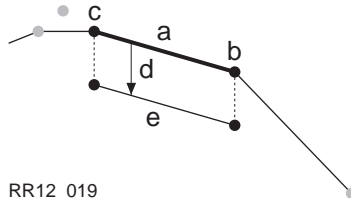

- a) X-Slope to shift
- b) Right stringline of the X-Slope
- c) Left stringline of the X-slope
- d) Negative vertical shift
- e) Shifted X-slope

RR12 019

11.5

Stake Offset and Stake Height Difference

Description

When conducting a stake out, the aim is usually to mark the position of geometric elements defined by the design. For example, in the graphic below, the catch point of a slope. A point can be staked either directly or indirectly. In the case of an directly staked out point the peg ends up at exactly the position of the point to be staked out. Staking the same point indirectly, the peg will be placed with a certain offset to the point.

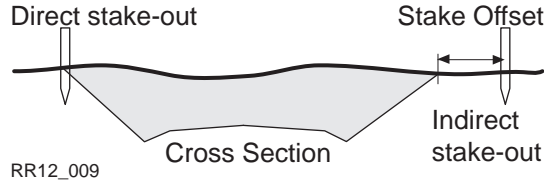

One reason to stake out a point indirectly is that the peg would not last long at the position of the actual point. In this example the peg staked out directly would be removed as soon as the excavation work starts.



Horizontal stake offsets are like shifts always defined perpendicular to the centre line of the layer the stringline(s) belongs to. For X-slopes and road crowns the stake offset is applied following the same rules as pointed out for horizontal shifts. Refer to "11.4 Shifts" for more information.

Stake offset

For each stake out method a horizontal and/or vertical offset may be defined. The stake offset and stake height difference are defined on the **General** page of the stake out. Refer to "11.6.2 Stake Offset / Height Difference Working Example" for information on defining stake offsets / height differences.

Sign convention for stake offset and height difference

The sign convention for stake offsets and height differences is identical to the one used for design shifts.

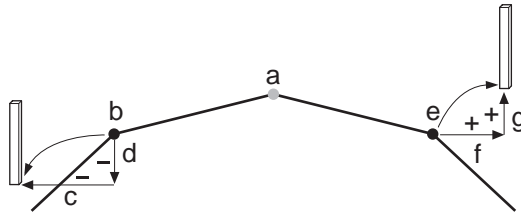

RR12_011

- a) Centre line
- b) Stringline on left side
- c) Negative stake offset
- d) Negative stake height difference
- e) Stringline on right side
- f) Positive stake offset
- g) Positive stake height difference

Plot page with stake offset and stake height difference

RoadRunner offers for all stake out methods a page showing a graphical representation of the measured position in relation to the cross section. If stake offset and/or stake height difference are used the plot shows the original cross section view of the design as well as the position to stake out. The position to stake out is marked by a cross.

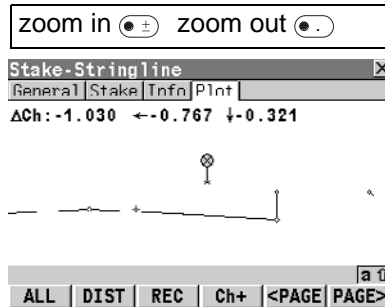

The position to stake out with the applied stake offset and/or height difference is indicated in the cross section plot by a cross.

11.6

11.6.1

Two positions

Two steps

Stake and Info Screens

Overview

When staking out you are first of all interested in finding the position you want to place the peg. In the next step you have to write the required information on the peg.

Stake out may be divided into two sequential steps:

Step	Description
1.	Find the position to place the peg.
2.	Mark the information on the peg that allows its final position to be determined.

The dialog used for stake out in RoadRunner reflects these two steps. One page, the **Stake** page, is used as a guide to the peg position and a second page, the **Info** page, indicates the values to mark on the peg.

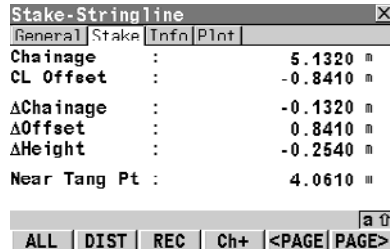

The screenshot shows a dialog box titled "Stake-Stringline" with a close button (X) in the top right corner. The dialog has four tabs: "General", "Stake", "Info", and "Print". The "Info" tab is currently selected. The dialog displays the following data:

Chainage	:	5.1320 m
CL Offset	:	-0.8410 m
Δ Chainage	:	-0.1320 m
Δ Offset	:	0.8410 m
Δ Height	:	-0.2540 m
Near Tang Pt	:	4.0610 m

At the bottom of the dialog, there is a navigation bar with buttons for "ALL", "DIST", "REC", "Ch+", "<PAGE", and "PAGE>".

The first step:

Stake - The **Stake** page is used for the first step of the actual stake out. It guides you to the position to be staked out. If the values for **Δ Chainage** and **Δ Offset** are close enough to 0 you are in the right position to place the peg.

Stake-Stringline		Print
General	Stake	Info
Strgl Task :	Stringline1	
Chainage :	5.1320 m	
CL Offset :	-0.8410 m	
Strgl Offset :	-0.8410 m	
Strgl Ht Diff :	0.2540 m	
CL Ht Diff :	0.2540 m	
CL Height :	419.6951 m	

					a	↑
ALL	DIST	REC	Ch+	<PAGE	PAGE>	

The second step:

Info - Shows the information to be marked on the peg for the construction worker or machine operator. The **Info** page is user definable.

Independent if staking out stringlines, X-slopes, slopes or road crowns the screen always shows these two pages. As the information to be left on the peg varies depending on the object to be staked out and the working methods used on the site the information page is for each stake method user definable. This allows to show all the required information in exactly the way needed.

The various checking methods use the same **Info** pages.

11.6.2

Stake Offset / Height Difference Working Example

Example

This example shows the differences between staking out with and without stake offset / height difference. A stringline, in this case the centre line, should be staked out. Once without an stake offset, and once using an stake offset of 1 m. The stake height difference stays zero in both cases.

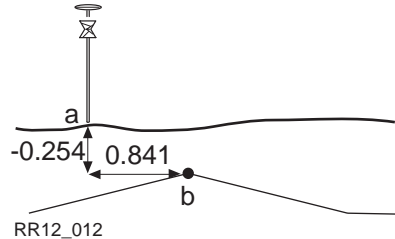

- h) Current position; Δ Offset: 0.841, Δ Height: -0.254
- i) Position to stake out

No stake offset

Stake-Stringline	
General	Stake
Chainage	: 5.1320 m
CL Offset	: -0.8410 m
Δ Chainage	: -0.1320 m
Δ Offset	: 0.8410 m
Δ Height	: -0.2540 m
Near Tang Pt	: 4.0610 m

ALL DIST REC Ch+ <PAGE PAGE>

Since, in this example, the stringline is also the centre line of the layer, the offset from the centre line **CL Offset** and delta offset to the reference line **Δ Offset** are equal but of opposite signs.

Stake-Stringline	
General	Stake
Strgl Task :	Stringline1
Chainage :	5.1320 m
CL Offset :	-0.8410 m
Strgl Offset :	-0.8410 m
Strgl Ht Diff :	0.2540 m
CL Ht Diff :	0.2540 m
CL Height :	419.6951 m

a ↑					
ALL	DIST	REC	Ch+	<PAGE	PAGE>

As no stake offset or stake height difference are used the values shown for stake out on the **Stake** page **ΔOffset** and **ΔHeight** are the same as shown on the **Info** page for **Strgl Offset** and **Strgl Ht Diff**.



Info pages are user definable. Depending on the configurations chosen your **Info** page may look different.

Defined stake offset

Stake offsets / height differences can be defined for every stake out on the **General** page. In this example a stake offset **Stake Offset: -1.000** of 1 m to the left is used. The stake height difference stays zero.

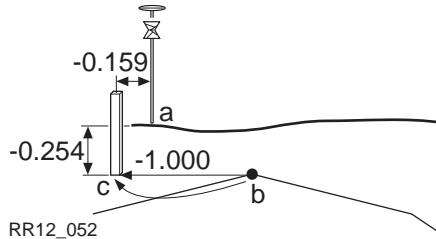

- a) Current position
- b) Stringline to stake out, in our case also the centre line
- c) Position to stake out = stringline + stake offset

Stake-Stringline	
General	Stake
Point ID :	CL005
Reflector Ht :	1.3000 m
def Chainage :	5.0000 m
Ch Increment :	5.0000 m
Stake Offset :	1.0000 m
Stake Ht Diff :	0.0000 m

Stake Offset and **Stake Ht Diff** are stored with the task and will be maintained when the task is restarted. Refer to "11.5 Stake Offset and Stake Height Difference" for information on how stake offsets are defined.

Use stake offset

Working with a stake offset of -1 m and a stake height difference of 0 m returns the following results for the same position:

Stake-Stringline	
General	Stake
Chainage :	5.1320 m
CL Offset :	-0.8410 m
ΔChainage :	-0.1320 m
ΔOffset :	-0.1590 m
ΔHeight :	-0.2540 m
Near Tang Pt :	4.0610 m

The horizontal offset **ΔOffset** from the position to stake out is now -0.159 m (0.841 - 1). All other values stay the same as when a stake-offset was not used.

Stake-Stringline	
General	Stake
Strgl Task :	Stringline1
Chainage :	5.1320 m
CL Offset :	-0.8410 m
Strgl Offset :	-0.8410 m
Strgl Ht Diff :	0.2540 m
CL Ht Diff :	0.2540 m
CL Height :	419.6951 m

ALL DIST REC Ch+ <PAGE PAGE>

The values on the **Info** page for **Strgl Offset** and **Strgl Ht Diff** now show how far the current position is away from the stringline.

If the peg is placed in its exact position, **ΔOffset** on the **Stake** page would be equal to zero. **Strgl Offset** on the **Info** page would show exactly the same value as that defined for **Stake Offset** on the **General** page.

11.7

11.7.1

Manual and design slopes

Methods for Slope Staking

Overview

RoadRunner offers a manual slope stake out and a slope stake out by design.

Type	Description
Manual slopes	The slope is defined manually by offsets and the slope ratio relative to a known centre line.
Design slope	The slope is nominated out of the full 3D design of the road job.

Four methods of slope stake out

Independent if using manual or design slopes the following four different methods are available:

Method	Description
General	A generic slope stake out method.
Reference point	Stake out of a reference peg with a defined offset from the catch point. Refer to "11.7.3 Slope Staking Using a Reference Point".
Batter rails	Stake out of batter rails with defined peg heights. Refer to "11.7.4 Slope Staking With Batter Rails".
Batter rails with a reference peg	Stake out of batter rails with a defined offset from the catch point. Refer to "11.7.5 Staking Batter Rails Using a Reference Point".

The method used for slope stake out **Slope Method** is selected as part of **RR Road Configuration**. Refer to "6.3 Configuration Settings for the Program - Road Config" for more information on choosing the slope method.

Extending design slopes

When using slopes generated by a design package the quality of the change from cut to fill or where slopes start and end depends a lot on the terrain model used for the project. Occasionally a cut is required where the design still shows a fill, or one of the lines defining the slope ends before intersecting with the natural surface.

RoadRunner can handle these different situations with a variety of slope extras. As soon as a measurement is taken outside of the defined design slope a message appears prompting if the slope should be extended. The extension of a line is always based on the end-tangent of the stringline. When moving back into the defined design a notification appears.

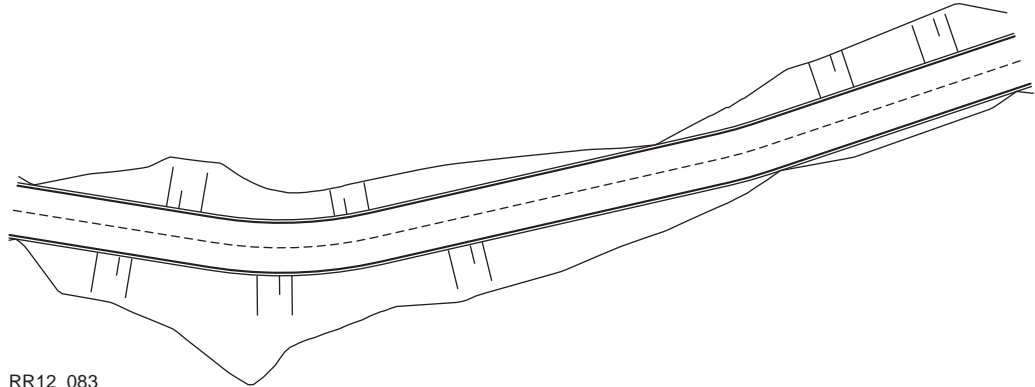

RR12_083

Slopes left and right of design changing from cut to fill.

11.7.2

General Slope Stake Out

Description

This general slope stake out method involves a generic approach to slope stake out. No special batter rails or reference point parameters are defined.

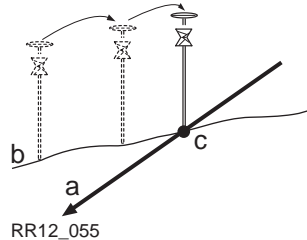

- a) Slope to stake out
- b) Natural surface
- c) Catch point

Slope method

Select **Slope Method: None** in **RR Road Configuration, General** page. Refer to "6.3 Configuration Settings for the Program - Road Config" for more information on choosing the slope method.

Workflow

As the natural surface is unknown the catch point can only be staked out iteratively. If staking out on a horizontal natural surface the values shown for **ΔOffsets** indicates how far the catch point is away. If the natural surface is not horizontal you may need more iterations.

11.7.3

Slope Staking Using a Reference Point

Description

When staking out slopes using the reference point method, the catch point of the slope is marked with a reference peg using a defined offset. The grade of the slope is marked and controlled by "grade checkers".

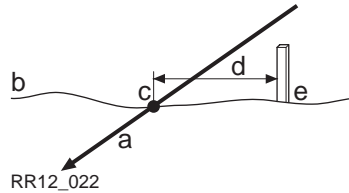

- a) Slope to stake out
- b) Natural surface
- c) Catch point of the slope
- d) Defined reference point offset **Ref Offset**
- e) Reference peg

The reference point offset guarantees that all pegs are placed with the same horizontal offset to the catch point.

Workflow

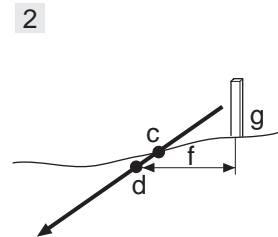
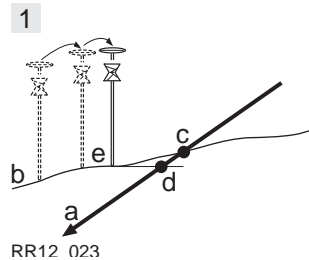

- a) Slope to stake out
- b) Natural surface
- c) Real catch point
- d) Projected catch point
- e) Approximate staked out catch point after three iterations
- f) Defined reference point offset **Ref Offset**
- g) Reference peg

Step	Description
1.	<p>The first step when staking out is to find the catch point of the slope. As the natural surface is unknown this has to be done iteratively. As soon as the measured position (e) is close enough to the real catch point (c), it may be used as the approximate catch point. Based on this approximate catch point, the projected catch point (d) on the slope is calculated.</p> <p>No reference point offset Ref Offset and no traveller height Traveller Ht are taken into account for this step. The projected catch point (d) is then used as a starting point for the stake out of the reference peg (g).</p>
2.	<p>The second step is to stake out the reference point relative to the projected catch point. Values in RoadRunner Stake Slope Refpoint, Stake page will guide you straight to the position to place the peg. The defined reference point offset Ref Offset (f) is already taken into account.</p> <p>The catch point is marked indirectly via the reference peg. Values to be marked on the reference peg can be found on RoadRunner Stake Slope Refpoint, Info page.</p>

The closer the real catch point and the approximated stake out catch point are, the closer the projected catch point gets to the real catch point.

Slope method to be used

Select **Slope Method: Reference Point** in **RR Road Configuration, General** page. Refer to "6.3 Configuration Settings for the Program - Road Config" for information on how to change the slope method.

11.7.4

Slope Staking With Batter Rails

Description

When staking out slopes with the batter rail method the grade of the slope is marked with a board. Using this method it is not necessary to stake out the catch point first.

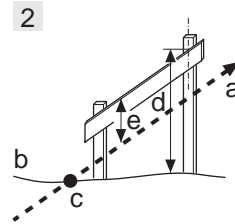
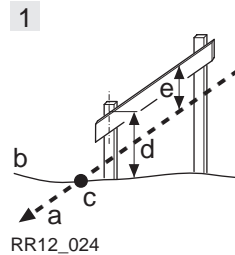

- 1 Batter rail for a cut
- 2 Batter rail for a fill
- a) Slope to stake out
- b) Natural surface
- c) Catch point of the slope
- d) Rail over ground **Rail over Grd**
- e) Rail over batter **Rail ov Batt**

The defined **Rail over Grd** should guarantee that the rails are positioned as high as possible, to make them easier to use.

Slope method to be used

Select **Slope Method: Batter Rail** in **RR Road Configuration, General** page. Refer to "6.3 Configuration Settings for the Program - Road Config" for information on how to change the slope method.

11.7.5

Staking Batter Rails Using a Reference Point

Description

This method is used if batter rails with a constant distance from the inner peg to the catch point are required.

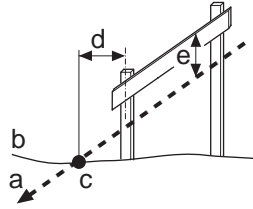

RR12_025

- a) Slope to stake out
- b) Natural surface
- c) Catch point of the slope
- d) Defined reference point offset **Ref offset**
- e) Height of the "traveller" **Traveller Ht**

Workflow

Staking out batter rails the reference peg method is separated in two steps.

Step	Description
1.	The first step is to stake out the catch point of the slope. The reference point offset Ref Offset and traveller height Traveller Ht are not taken in account in this step. Based on this approximate catch point the projected catch point on the slope is calculated. The projected catch point is used as a starting point for the stake out of the reference peg.
2.	The second step is to stake out the reference point relative to the projected catch point. Values in RoadRunner Stake Slope Refpoint, Stake page will guide you straight to the position to place the peg. The defined reference point offset Ref Offset and traveller height Traveller Ht are taken into account. Values to be marked on the batter can be found on RoadRunner Stake Slope Refpoint, Info page.

Slope method

Select **Slope Method: Reference Batter** in **RR Road Configuration, General** page. Refer to "6.3 Configuration Settings for the Program - Road Config" for information on how to change the slope method.

11.8

Chainage or Station Equations

Description

Chainage or station equations are used to adjust the alignment chainage or station. The most common reason for doing so is the insertion or removal of curves during the design process. Inserting or removing a curve would require recalculating the chainage or station of an entire alignment. Using chainage or station equations eliminates this need. Chainage or station equations can create either a gap or an overlap as shown in the following diagrams.

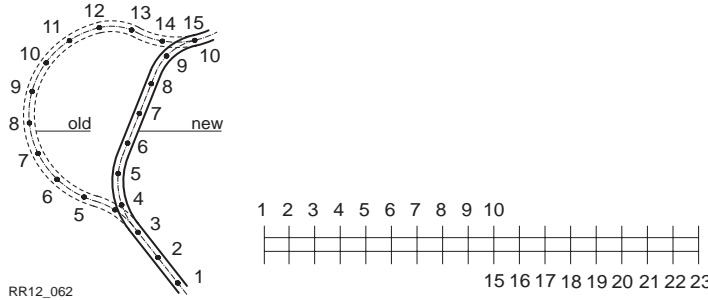

Gap chainage or station equation. Chainage or station back 10 = chainage or station ahead 15.

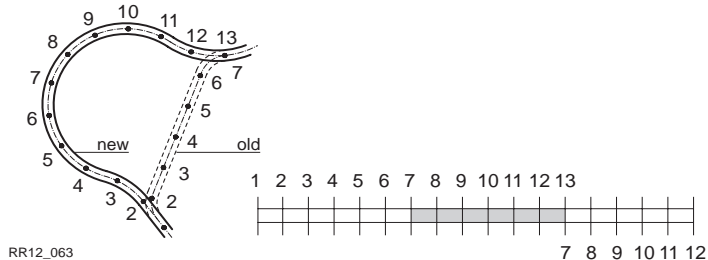

Overlap chainage or station equation. Chainage or station back 13 = chainage or station ahead 7.

Multiple chainage or station

In the case of the overlap shown in the example, the chainages or stations between seven and thirteen appear twice. When typing in a duplicate chainage or station, a message box prompts if the previous selected chainage or station should be used again or if a new one should be selected from all existing chainage or station equations.

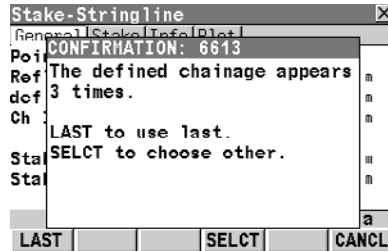

LAST (F1)

To use the previously selected chainage or station equation for the entered chainage or station.

SELECT (F4)

To select the chainage or station out of a list of all available chainage or station equations for the entered chainage or station.

Example

As more than one chainage or station equation is possible a chainage or station can appear more than twice on a design. In this example the chainages or stations 11 to 13 appear three times.



Overlap chainage or station equation. Chainage back 13 = chainage ahead 7 and chainage back 15 = chainage ahead 11.

If typing in chainage or station 12 in this example in **RR Multiple Chainage** to select the right chainage or station looks as follows:

Nr	Ahead	Back
1	0.000	----
2	7.000	13.000
3	11.000	15.000

CONT				MORE	
------	--	--	--	------	--

CONT (F1)

To select the highlighted chainage or station equation and return to the stake out dialog.

MORE (F5)

To switch the last column to show the end chainage or station of the chainage or station equation.

Description of columns

Column	Description
End	Shows the end chainage or station for the chainage or station equation, reads in our example 13.000 for Nr 1 , 15.000 for Nr 2 and 24.000 for Nr 3 . End shows till which chainage or station the current chainage or station equation is valid. As for the first part of the alignment no chainage or station equation exists Ahead stays empty for the first row.

11.9

Working Corridor

Description

A working corridor defines the valid offset range left and right of the centre line. When working with irregular alignments such as traffic islands and parking lots working corridors are useful to avoid displaying results from the wrong centre line element.

The example below shows the result you would get if working without defined working corridor. For the measured position (b) RoadRunner finds the centre line point (c) with the minimum perpendicular offset (f).

With a defined working corridor (e) RoadRunner would display with a message telling you that the measured position is outside of the defined centre line.

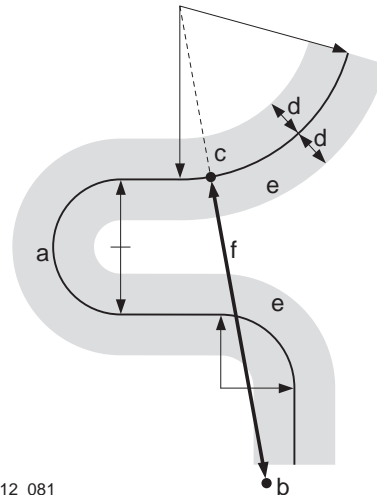

RR12_081

- a) Centre line
- b) Measured position
- c) Projected point on the centre line
- d) Defined offset range for the working corridor
- e) Working corridor
- f) Offset from the centre line if no working corridor is used

The working corridor is defined via **Work Corrid** in **RR Road Configuration, General** page. Refer to "6.5 Auto Positioning (TPS only)" for information on **RR Road Configuration**.

12**Understanding the Geometry**

12.1**Horizontal and Vertical Geometry Elements**

Horizontal alignment

RoadRunner supports the following elements in the horizontal component of alignments:

- Straights
- Arcs
- Clothoids, entry and exit as well as partial
- Cubic parabolas
- Full/Partial Bloss curves (parabola of degree five)
- Multipoints, all elements that cannot be described by one of the previous types are represented by discrete points along the curve. For example, a line parallel to a clothoid.

Vertical alignment

RoadRunner supports the following elements in the vertical component of alignments:

- Straights
 - Arcs
 - Quadratic parabolas
 - Multipoints, all elements that cannot be described by one of the previous types are represented by discrete points along the curve.
-

12.2

Horizontal and Vertical Shifts

Description

Horizontal and vertical shifts are added when creating a task within the selection wizard. RoadRunner offers the following four different types of shifts:

- Constant
- Linear
- Parabolic
- Reverse Curve

A shift is always an overlay of the existing design and is stored with the task. In the case of a horizontal alignment the shift is applied perpendicular to the centre line. For the vertical part of the alignment, shifts are applied following the plumb line.

Constant

A constant shift is applied from the begin chainage of the shift to the end chainage of the shift.

Linear

The difference between the shift at the begin chainage and the shift defined at the end chainage is distributed in a linear fashion.

Parabolic

The difference between the shift at the begin chainage and the shift defined at the end chainage is distributed using a cubic parabola. Parabolic shifts allow a smooth transition between the existing curve and the shifted part.

Reverse curve

Two arcs with the same radius are used to distribute the shift. As for parabolic shifts, reverse curves guarantee a smooth transition between the existing curve and the shifted part.

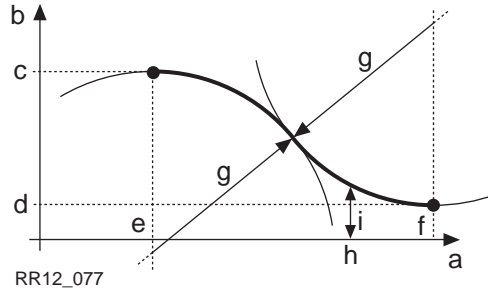

- a) Chainage
- b) Shift
- c) Start shift at chainage (e)
- d) End shift at chainage (f)
- e) Start chainage of the shift
- f) End chainage of the shift
- g) Radius of the two arcs used as transition curve
- h) Random chainage between (e) and (f)
- i) Shift applied at chainage (h)

RR12_077

Behavior before/after the shifted area

RoadRunner offers three possibilities how the area before the start chainage and after the end chainage of the shift should be treated.

Type	Description
None	The curve exists between the start chainage and end chainage of the shift.
Step	Outside of the defined shift area the original design is used. This means a "step" will appear at the start and/or end of the shifted area.
Parallel	The start shift is used from the start of the alignment till the start chainage and the end shift from the end chainage on till the end of the alignment.

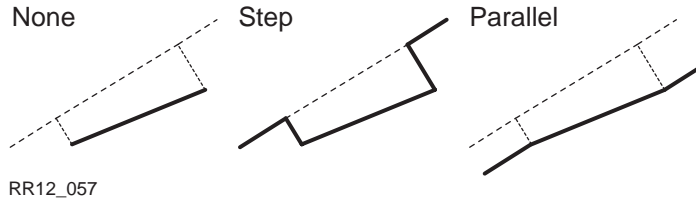

The three possibilities for curve behavior outside of the shifted area.

12.3

Extension of Stringlines

Description

Whenever stringlines need to be extended, for example, at the start and end area of an alignment or slope. The projection of the stringline is made using the tangent of the start/end point of the stringline.

In this case a warning appears informing that the original design is exceeded. As soon as a measured position is within the design area once again, RoadRunner will notify you.

Concept

When expanding the centreline the geometry of the last element of the centreline will be continued (for example: a centreline that ends with an arc will be continued with an arc of the same radius).

The chosen setting for the expansion stays active whilst the task is active.



RR12_090

- a) Centreline
- b) Extended centreline

Method

Description

When staking-out in the region of the start/end area of the design centreline, situations occur where an expansion of the centreline is useful. As soon as dropping outside the defined centreline RoadRunner will prompt if and with which method the centreline should be expanded.

Screen

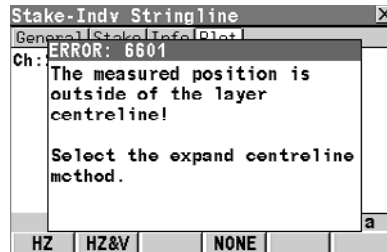

HZ (F1)

Only the horizontal alignment is expanded.

HZ&V (F2)

the horizontal and the vertical alignment are expanded.

NONE (F4)

Will not expand the centreline at all, and for all measurements outside the centreline no information is displayed.



The extension of a stringline is made following its start/end tangent. Outside of the original design area correct results cannot be guaranteed.

13

Quick Start Tutorial (Advanced Mode)

13.1

Overview

Description

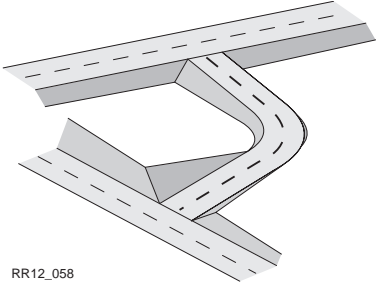
Description	
<p>This tutorial guides you through some basic RoadRunner techniques as you stake and check a bike path.</p>	 <p>RR12_058</p>
<p>Designed on a CAD System, the data for the bike path has been converted into the onboard format. The design is a short ramp that connects a road with an already existing part of the bike path.</p>	
<p>In this tutorial chapter, you will learn how to:</p> <ul style="list-style-type: none"> * Create a project that includes your road data * Change your road configurations * Select the element to stake out * Stake out the centre line of the design * Find catch points for slopes and place batter rails * Check a road layer surface * Shift design to fit existing road level 	
<p>This chapter is separated in five exercises. You can work through the entire tutorial or complete each exercise at a time.</p>	

Graphical overview Horz / Vert alignments

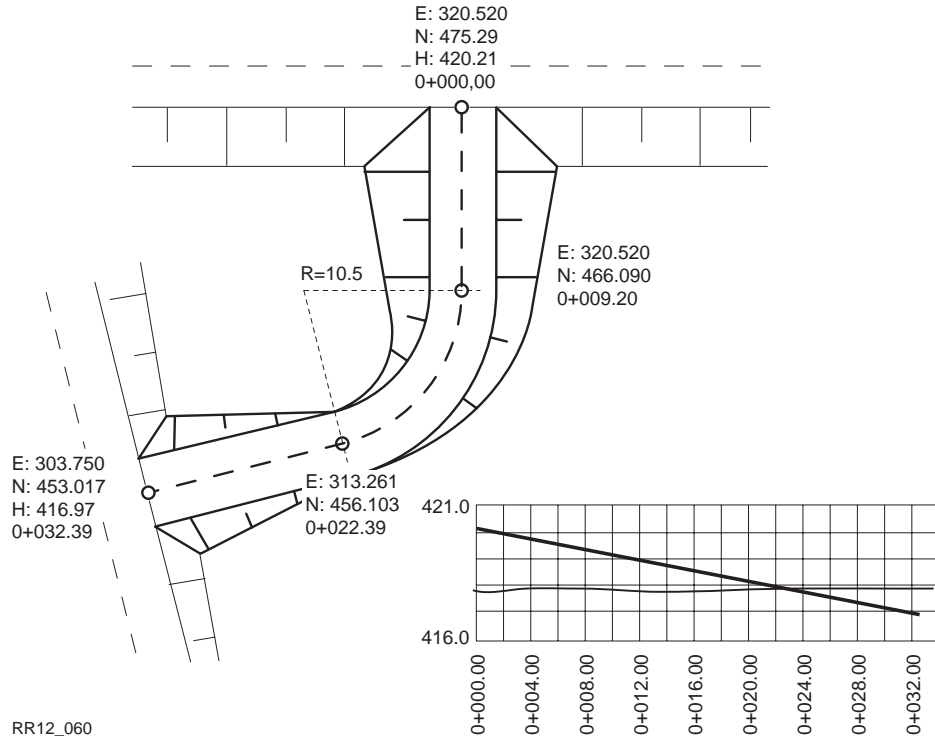

The data representing a bike bath connecting two existing roads is used during your tutorial.

Graphical overview

Cross sections

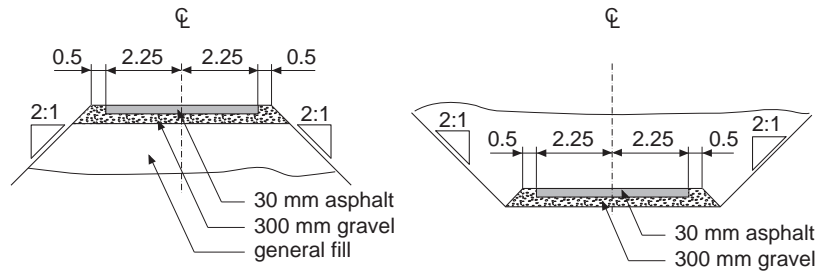

RR12_061

The bike path changes from a fill to a cut. Two different types of cross sections are used.

13.2

Exercise 1a: Setting Up and Getting Started

Description

- This exercise includes a short description of how to define a local coordinate system. This tutorial can only give you a short overview about the settings you need. It is recommended to read the regarding chapters in the GPS/TPS Technical Reference Manual.
- In this exercise only one way to define a local coordinate system is described. If you are already familiar with your system you can choose your normal way of defining a local coordinate system.

Uploading the data

- This exercise uses the tutorial data distributed with the "SmartWorx DVD".
- Copy all data from GPS1200 or TPS1200\GPS1200 or TPS1200_SampleData\Applications\RoadRunner\Tutorial\Onboard\Exercise1\ to the CF card under \DBX\.
- All parts of this task can be completed in the office.

Setting up the TPS

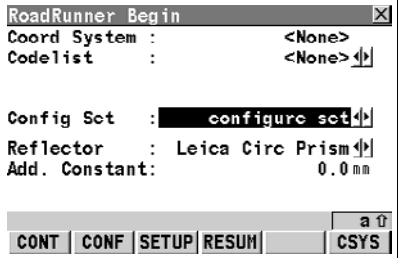
	Description	
1.	Set up in the upper left corner of your survey area.	
2.	Turn on and press PROG . Select RoadRunner .	
3.	RoadRunner Begin. Select Coord System: , Select Codelist: , Select Config Set: and Select Reflector: . Press SETUP (F3) .	

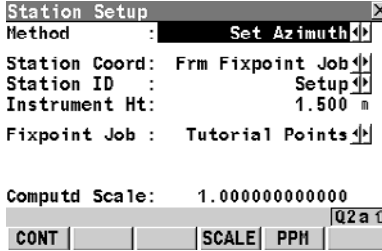
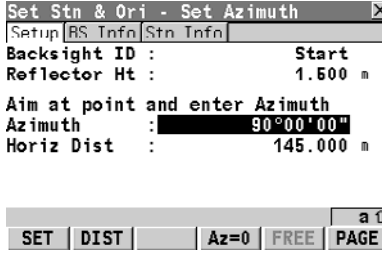
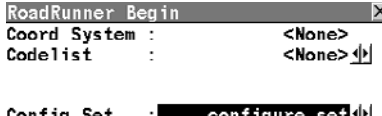
	Description	
4.	<p>Station Setup.</p> <p>Select Method: Set Azimuth.</p> <p>Select Station Coord: Frm Fixpoint Job.</p> <p>Select Station ID: Setup.</p> <p>The coordinates of this point are: East=305, North=475, Height=418.</p> <p>Enter the instrument height Instrument Ht:</p> <p>Select Fixpoint Job: Tutorial Points.</p> <p>Press CONT (F1) to continue.</p>	
5.	<p>Set Stn & Ori - Set Azimuth.</p> <p>Enter Backsight ID: Start</p> <p>Enter the reflector height Reflector Ht:</p> <p>Enter Azimuth: 100.0000 if working with gon.</p> <p>Enter Azimuth: 90 if working with degrees.</p> <p>Aim the instrument in the direction of the start point of the tutorial alignment.</p> <p>Press SET (F1).</p>	
6.	<p>Press OK (F4) to complete the setup.</p>	

Setting up the GPS

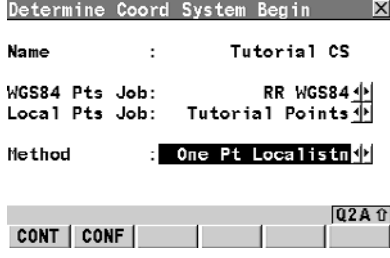
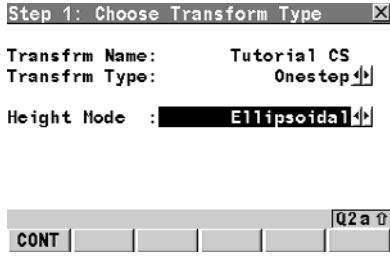
	Description	
	Define a local coordinate system by using a one-step transformation.	
	Before you start with the definition of the new coordinate system for the tutorial, configure the sensor as a rover following the "GPS1200 Technical Reference Manual".	
1.	Turn on and press PROG . Select Determine Coordinate System .	
2.	Determine Coord System Begin Select Name: Tutorial CS Select WGS84 Pts Job: RR WGS84 Select Local Pts Job: Tutorial Points Select Method: One Pt Localistn Press CONT (F1) to continue.	
3.	Step 1: Choose Transform Type Select Transfrm Type: Onestep Select Height Model: Ellipsoidal Press CONT (F1) to continue.	

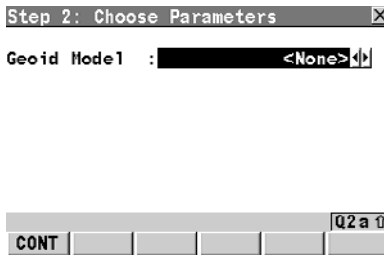
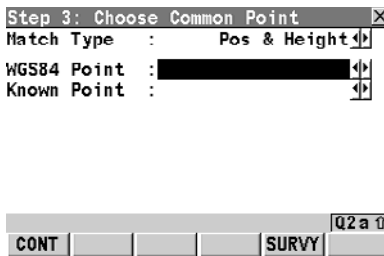
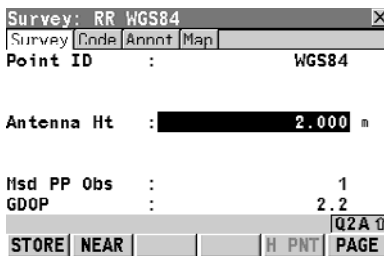
	Description	
4.	<p>Step 2: Choose Parameters</p> <p>Select Geoid Model: None</p> <p>Press CONT (F1) to continue.</p>	 <p>Step 2: Choose Parameters</p> <p>Geoid Model : <None></p> <p>CONT Q2 a</p>
5.	<p>Step 3: Choose Common Point</p> <p>Highlight WGS84 Point..</p> <p>Press SURVY (F5)</p>	 <p>Step 3: Choose Common Point</p> <p>Match Type : Pos & Height</p> <p>WGS84 Point : [Selected]</p> <p>Known Point :</p> <p>CONT SURVY Q2 a</p>
6.	<p>Survey: RR WGS84, Survey page</p> <p>Enter Point ID: Point WGS84.</p> <p>Enter the antenna height Antenna Ht..</p> <p>Place your pole in one of the corners of the area you will use for the tutorial example. Position is also marked in the drawing.</p> <p>Press OCUPY (F1), STOP (F1) and STORE (F1) to measure and store the point.</p>	 <p>Survey: RR WGS84</p> <p>Point ID : WGS84</p> <p>Antenna Ht : 2.000 m</p> <p>Hsd PP Obs : 1</p> <p>GDOP : 2.2</p> <p>STORE NEAR H PNT PAGE</p>

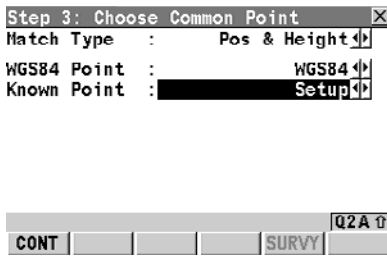
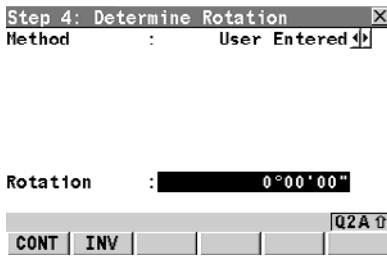
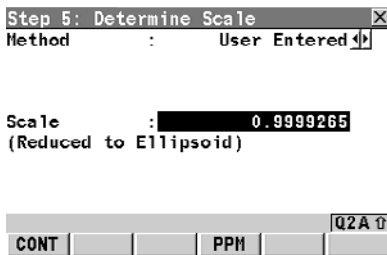
	Description	
7.	<p>Step 3: Choose Common Point</p> <p>Select WGS84 Point: WGS84</p> <p>Select Known Point: Setup.</p> <p>The coordinates of this point are: East=305, North=475, Height=418.</p> <p>Press CONT (F1) to continue.</p>	 <p>Step 3: Choose Common Point</p> <p>Match Type : Pos & Height</p> <p>WGS84 Point : WGS84</p> <p>Known Point : Setup</p> <p>CONT SURVY Q2A</p>
8.	<p>Step 4: Determine Rotation</p> <p>Select Method: User Entered</p> <p>Enter the rotation Rotation: for your test area.</p> <p>Press CONT (F1) to continue.</p>	 <p>Step 4: Determine Rotation</p> <p>Method : User Entered</p> <p>Rotation : 0°00'00"</p> <p>CONT INV Q2A</p>
9.	<p>Step 5: Determine Scale</p> <p>Select Method: User Entered</p> <p>The Scale: should be close to 1.000.</p> <p>Press CONT (F1) to continue.</p>	 <p>Step 5: Determine Scale</p> <p>Method : User Entered</p> <p>Scale : 0.9999265 (Reduced to Ellipsoid)</p> <p>CONT PPM Q2A</p>

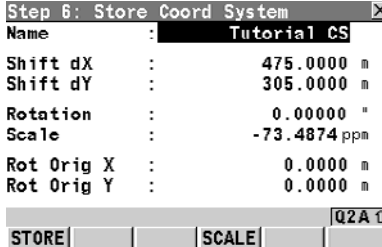
	Description	
10.	<p>Step 6: Store Coord System</p> <p>Press STORE (F1) to confirm the newly created coordinate system</p>	 <pre> Step 6: Store Coord System [X] Name : Tutorial CS Shift dX : 475.0000 m Shift dY : 305.0000 m Rotation : 0.00000 ° Scale : -73.4874 ppm Rot Orig X : 0.0000 m Rot Orig Y : 0.0000 m STORE [] [] SCALE [] [] Q2A ↑ </pre>

You have created the new local coordinate system **Tutorial CS** for the tutorial. The measurement job **Meas Job**: of a RoadRunner project defines which coordinate system is used by default. To ensure that you are using the right coordinate system change the current coordinate system of **Job: Tutorial Meas**. Refer to the "GPS1200 Technical Reference Manual" for information on changing coordinate systems of jobs.

13.3

Exercise 1b: Creating the Project and Task and also Configuring

Description

- In this exercise, you will create a new project that contains the road data converted from the original CAD design data. To make sure that the right configurations are used you will need to check them. Then the first element to stake out, the centre line of the bike path, is selected.
- Most of the time, when working on a construction site, it is not possible to finish a task in one go. RoadRunner deals with this by "remembering" the tasks you have been working on. The special shifts, names and other settings of the task you have defined are stored and can be called up again. This makes it also possible to prepare the tasks in the office, where all the paper plans, CAD drawings, recent updates and a good cup of coffee are available.

Uploading the data

- This exercise uses the tutorial data distributed with the "SmartWorx DVD".
- Copy all data from GPS1200 or TPS1200\GPS1200 or TPS1200_SampleData\Applications\RoadRunner\Tutorial\Onboard\Exercise1\ to the CF card under \DBX\.
- All parts of this task can be completed in the office.

Creating a new project

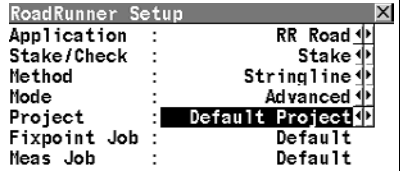
	Description	
1.	Press CONT (F1) to access RoadRunner Setup . (these steps continue from Exercise 1a)	
2.	Highlight and open the choicelist for Project .	 The screenshot shows a menu titled "RoadRunner Setup" with the following options: Application : RR Road, Stake/Check : Stake, Method : Stringline, Mode : Advanced, Project : Default Project (highlighted), Fixpoint Job : Default, Meas Job : Default.

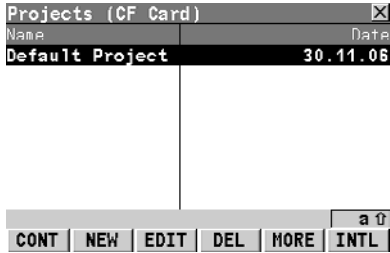
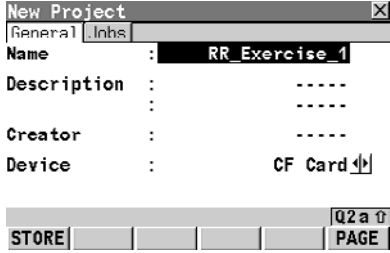
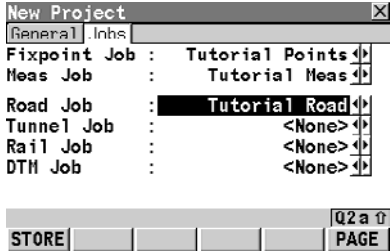
	Description	
3.	<p>Press NEW (F2).</p> <p>When creating a project, RoadRunner lets you group the jobs - the fixpoint job, the measurement job, the road job, and the DTM job to give you faster access.</p>	
4.	<p>The General page.</p> <p>Enter Project Name: RR_Exercise_1,</p> <p>Enter a description (optional) Description:,</p> <p>Enter a name (optional) Creator: and</p> <p>Select the storage device Device: CF Card.</p> <p>Press PAGE (F6) to move to the Jobs page.</p>	
5.	<p>The Jobs page.</p> <p>Highlight and open the choicelist for Fixpoint Job.</p> <p>Highlight and select the job Tutorial Points.</p> <p>In a fixpoint job all the control data needed in the field is stored. Control data can be points with known coordinates used for a TPS set-up or points used to determine a GPS coordinate system.</p> <p>Press CONT (F1) to continue.</p>	

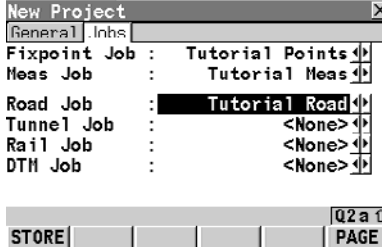
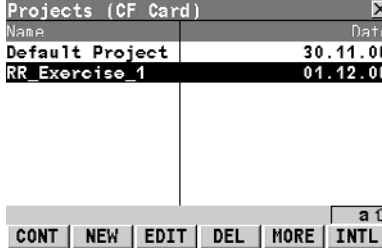
	Description	
6.	<p>Select the other jobs in the same way: Select Meas Job: Tutorial Meas, Select Road Job: Tutorial Road and Select DTM Job: None. Press STORE (F1) to store the project.</p>	
7.	<p>The new project RR_Exercise_1 has been created. When working with the project the next time it is no longer necessary to select all different parts that belong to the project separately. When the project is selected all parts come with it. This helps to make the access easier and avoids errors based on a wrong selection. Press CONT (F1) to access RoadRunner Setup.</p>	

Understanding the geometry and the tasks

- Before the actual earthworks start the centre line of the new bike path should be staked out to give an overview of where it will run.
- RoadRunner differentiates between the pure data stored in your road job and the tasks you create based on them. For example, the centre line to stake out exists as a line stored in the road job containing all information about the geometry of the line. If you stake it out this pure geometry information is not enough. You define special shifts or decide that the line should only be staked out within a certain chainage range. The same line in the road



job can be staked out in different ways. Such a definition of how a certain element is staked out is called a task.

- In the following part you will create a task for the stake out of the centre line.

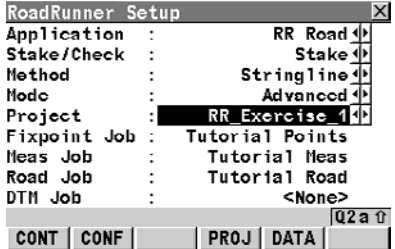
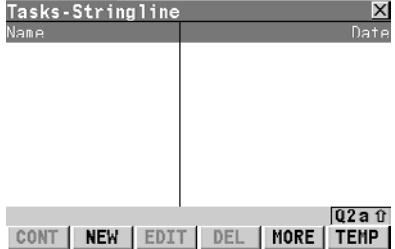
Creating a new task

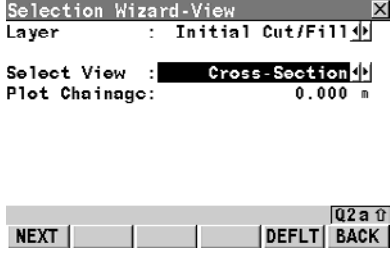
	Description					
8.	Select Application: RR Road , Select Stake/Check: Stake , Select Method: Stringline , Select Mode: Advanced , Ensure Project: RR_Exercise_1 is selected. Press CONT (F1) to access Task Management .	 <p>The screenshot shows the 'RoadRunner Setup' dialog box with the following settings:</p> <ul style="list-style-type: none"> Application : RR Road Stake/Check : Stake Method : Stringline Mode : Advanced Project : RR_Exercise_1 Fixpoint Job : Tutorial Points Heas Job : Tutorial Heas Road Job : Tutorial Road DTM Job : <None> <p>At the bottom, there are buttons for CONT, CONF, PROJ, DATA, and Q2a ↑.</p>				
9.	Press NEW (F2) to start the Selection Wizard. The selection wizard guides you through the selection of the new task. The new task is created when you reach the last screen of the Selection Wizard and end it with FINSH (F1) .	 <p>The screenshot shows the 'Tasks-Stringline' dialog box with a table structure:</p> <table border="1" data-bbox="1110 605 1506 792"> <thead> <tr> <th data-bbox="1110 605 1289 624">Name</th> <th data-bbox="1289 605 1506 624">Data</th> </tr> </thead> <tbody> <tr> <td> </td> <td> </td> </tr> </tbody> </table> <p>At the bottom, there are buttons for CONT, NEW, EDIT, DEL, MORE, and TEMP, along with a Q2a ↑ button.</p>	Name	Data		
Name	Data					

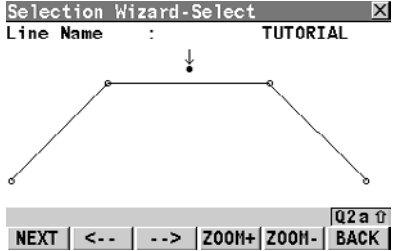
	Description	
10.	<p>Select Task Type: Stringline. Enter Task Name: Bike CL. Select Use Zig Zag: No. Select Shift Horiztl: None. Select Shift Verticl: None. Press NEXT (F1) to continue.</p>	
11.	<p>Select Layer: Initial Cut/Fill. RoadRunner can store different layers of a road. This makes it possible to store, for example, the final surface of the pavement as well as the surface for the first cut or fill. The centre line you stake out is shown on all layers.</p> <p>Select Select View: Cross-Section as you will select the centre line of the bike path in a cross section view of the design.</p> <p>The Plot Chainage: for the cross section is by default the start chainage of your alignment.</p> <p>Press NEXT (F1) to continue.</p>	

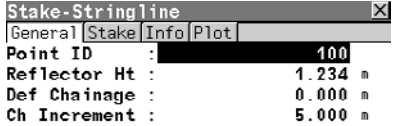
	Description	
12.	<p>Select Line Name: TUTORIAL. Select this line by using the (F2) and (F3) keys. The stringline name is the name defined during the conversion in LEICA Geo Office or the name of the stringline from the design package.</p> <p>Press NEXT (F1) to continue.</p>	
13.	<p>Select Stake Mode: 3D as you are also interested in the height of the centre line.</p> <p>Select Use Min/Max: No as you want to use the whole length of the centre line.</p> <p>Press FINSH (F1) to confirm the changes, end the Selection Wizard and create the new task.</p> <p>The new task you have created is stored with all the defined settings as part of the project. To run the stake out it is only necessary to call up the task again.</p>	
14.	<p>You are now ready to stake the bike path centre line.</p>	

Checking/Changing the configurations

Configurations define how the application appears and how it behaves. The configurations are separated in two groups:

- Project configurations, they are common for the whole project. For example how chainages are displayed.
- Road configurations, they are road specific. For example the working corridor left and right of the alignment.

All configurations can be stored in configuration sets.

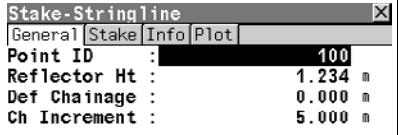
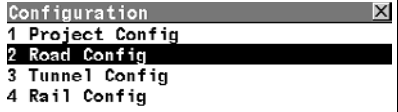
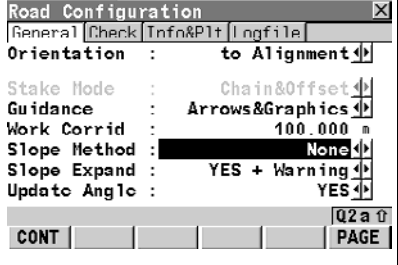
	Description	
15.	Press SHIFT CONF (F2) to access Configuration .	
16.	Choose Road Config .	
17.	<p>The General page.</p> <p>Select Orientate: to Alignment.</p> <p>The Stake Mode: changes to Chain & Offset</p> <p>Select Guidance: Arrows & Graphics.</p> <p>Select Work Corrid: 10.000m to define the working corridor left and right of the centre line.</p> <p>Press PAGE (F6) to move to the Check page.</p>	

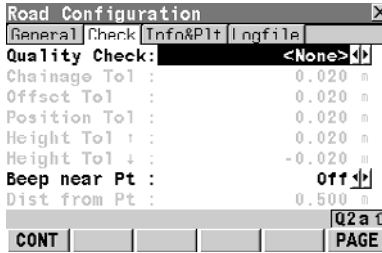
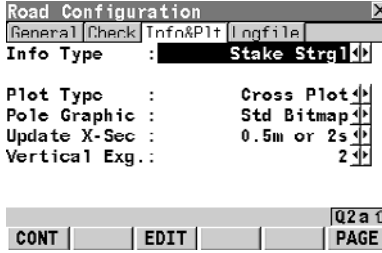
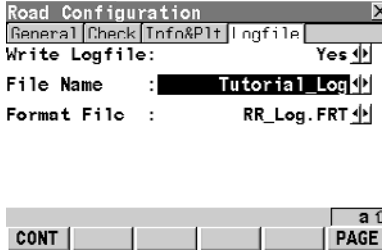
	Description	
18.	<p>Select Quality Check:None,</p> <p>Select Beep near Pt:Off.</p> <p>Press PAGE (F6) to move to the Info&Plt page.</p>	 <p>Road Configuration [X]</p> <p>General Check Info&Plt logfile</p> <p>Quality Check: <None></p> <p>Chainage Tol : 0.020</p> <p>Offset Tol : 0.020</p> <p>Position Tol : 0.020</p> <p>Height Tol : 0.020</p> <p>Height Tol : -0.020</p> <p>Beep near Pt : Off</p> <p>Dist from Pt : 0.500</p> <p>Q2a</p> <p>CONT PAGE</p>
19.	<p>Select Info Type: Stake Strgl.</p> <p>Select Plot Type: Cross Plot.</p> <p>Select Update X-Sec: 0.5m or 2s for the update frequency of the cross section view.</p> <p>Select Vertical Exg: 2 for the vertical exaggeration for the cross-section plot.</p> <p>Press PAGE (F6) to move to the Logfile page.</p>	 <p>Road Configuration [X]</p> <p>General Check Info&Plt logfile</p> <p>Info Type : Stake Strgl</p> <p>Plot Type : Cross Plot</p> <p>Pole Graphic : Std Bitmap</p> <p>Update X-Sec : 0.5m or 2s</p> <p>Vertical Exg. : 2</p> <p>Q2a</p> <p>CONT EDIT PAGE</p>
20.	<p>Select Write Logfile: Yes. Points are stored in the measurement job as well as the log file.</p> <p>Select File Name: Tutorial_Log.</p> <p>Select Format File: RR_Log. Variables defined in the chosen format file are written to the log file.</p> <p>Press CONT (F1) to continue.</p>	 <p>Road Configuration [X]</p> <p>General Check Info&Plt logfile</p> <p>Write Logfile: Yes</p> <p>File Name : Tutorial_Log</p> <p>Format File : RR_Log.FRT</p> <p>a</p> <p>CONT PAGE</p>

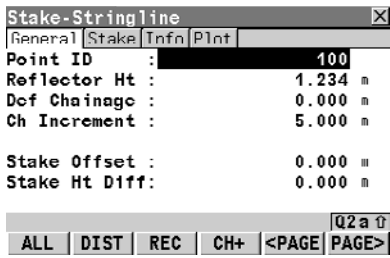
	Description	
21.	All changes are applied to the configuration set you have chosen before and stored with it. This means the next time you select the configuration set RoadRunner appears in the way you have defined it. You are ready to stake the bike path centre line.	 <p>Stake-Stringline [X]</p> <p>General Stake Info Plot</p> <p>Point ID : 100</p> <p>Reflector Ht : 1.234 m</p> <p>Def Chainage : 0.000 m</p> <p>Ch Increment : 5.000 m</p> <p>Stake Offset : 0.000 m</p> <p>Stake Ht Diff: 0.000 m</p> <p>Q2a ↑</p> <p>ALL DIST REC CH+ <PAGE PAGE></p>

13.4

Exercise 2: Staking the Centre Line

Description

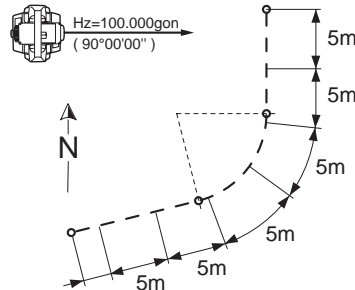

RR12_059

Pegs to place every 5 m and on every start/end point of a segment (=tangent point).

- In this exercise you will stake out the centre line of the bike path defined as a task "Bike_CL" in the previous exercise. For the centre line a peg every 5 m and one at every start and endpoint of an element, the tangent points, should be placed.

Preparation

- To run this exercise you need an open space of about 30 x 30 m and 10 pegs.

Uploading the data

- This exercise uses the tutorial data distributed with the "SmartWorx DVD".
- Copy all data from GPS1200 or TPS1200\GPS1200 or TPS1200_SampleData\Applications\RoadRunner\Tutorial\Onboard\Exercise2\ to the CF card under \DBX\.
- If you continue from Exercise 1 you can use RR_Exercise_1 as well.

Selecting the project and the task

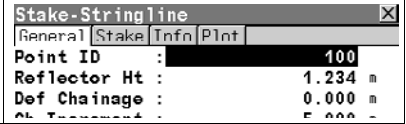
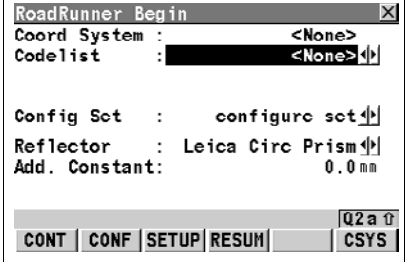
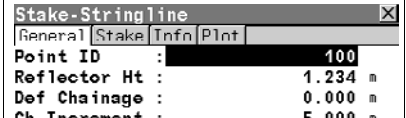
Description Option 1 - Continuing from Exercise 1	
1.	<p>If you have just completed Exercise 1a/1b and have not changed screens, then you are ready to stake the bike path centre line.</p> 
Description Option 2 - Continuing from Exercise 1	
1.	<p>If you have just completed Exercise 1a/1b and have either turned off the instrument or exited from the RoadRunner program, the following steps apply.</p>
2.	<p>Turn on and press PROG. Select RoadRunner.</p>
3.	<p>Press RESUM (F4) to simply start up the last task that you have been working on.</p> 
4.	<p>You are ready to stake the bike path centre line.</p> 

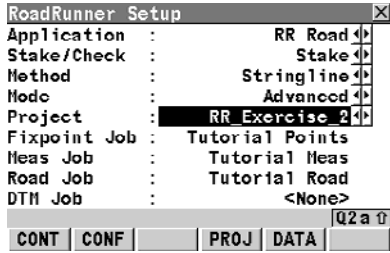
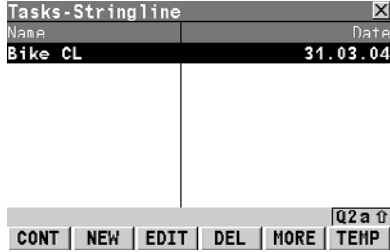
Description Option 3 - Starting with Exercise 2						
1.	Press CONT (F1) to access RoadRunner Setup . (these steps continue from Exercise 1a)					
2.	<p>Select Application: RR Road,</p> <p>Select Stake/Check: Stake,</p> <p>Select Method: Stringline,</p> <p>Select Mode: Advanced,</p> <p>Ensure Project: RR_Exercise_2 is selected.</p> <p>Press CONT (F1) to access Task Management.</p>	 <p>RoadRunner Setup</p> <p>Application : RR Road</p> <p>Stake/Check : Stake</p> <p>Method : Stringline</p> <p>Mode : Advanced</p> <p>Project : RR_Exercise_2</p> <p>Fixpoint Job : Tutorial Points</p> <p>Meas Job : Tutorial Meas</p> <p>Road Job : Tutorial Road</p> <p>DTM Job : <None></p> <p>CONT CONF PROJ DATA Q2a ↑</p>				
3.	<p>Highlight and select the existing task Bike CL.</p> <p>Press CONT (F1).</p>	 <p>Tasks-Stringline</p> <table border="1"> <thead> <tr> <th>Name</th> <th>Date</th> </tr> </thead> <tbody> <tr> <td>Bike CL</td> <td>31.03.04</td> </tr> </tbody> </table> <p>CONT NEW EDIT DEL MORE TEMP Q2a ↑</p>	Name	Date	Bike CL	31.03.04
Name	Date					
Bike CL	31.03.04					

Staking the centre line

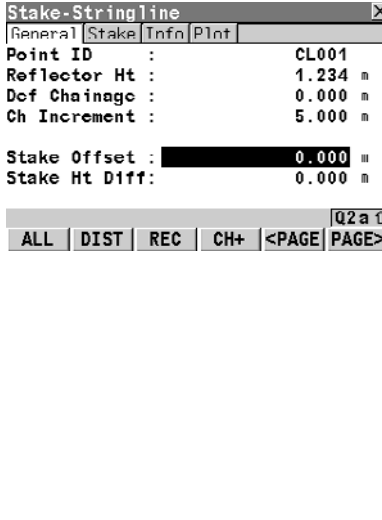
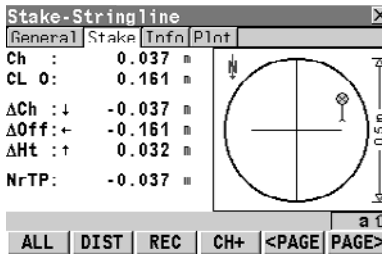
	Description	
1.	<p>The General page. On this page you define the point ID, reflector height for TPS, antenna height for GPS, at which chainage your stake-out should start, which chainage increment should be used and stake offsets.</p> <p>Enter a point ID Point ID: CL001.</p> <p>Enter the reflector height Reflector Ht.: for TPS</p> <p>Enter the antenna height Antenna Ht.: for GPS</p> <p>Enter Def Chainage: 0.000. The chainage for the first point you stake out is zero.</p> <p>Enter Ch Increment: 5.000. No increment is required if staking random chainages.</p> <p>Leave Stake Offset: and Stake Ht Diff: at 0.</p> <p>Press PAGE (F6) to change to the Stake page.</p>	
2.	<p>The Stake page. you see the difference between the current position and the position to stake out. The bulls eye on the right hand side gives you a graphical feedback of your position relative to the point to stake out.</p> <p>As Orientation: To Alignment has been chosen in Configuration the bulls eye is relative to the centreline.</p>	

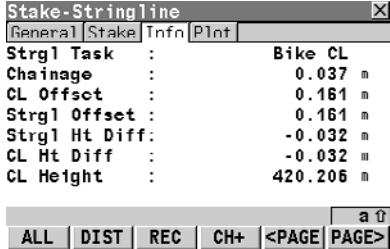
	Description															
	<p>The bulls eye is orientated relative to the centreline, with the tangent of the centreline running from 6 o'clock to 12 o'clock.</p> <p>When working in the tracking mode the delta values get populated instantaneously. Press DIST (F2) to populate this page with the values for the current measured position.</p> <p>The three delta values on this page show you the difference between the current position and the position to stake out. Bring the values for ΔChainage: and ΔOffset: as close to zero as required. Mark the position of the start point of the centre line.</p> <p>Press PAGE (F6) to move to the Info page.</p>															
3.	<p>The Info page. This page is user definable. This gives you the advantage that you can configure the Info page to display the information you need. If the radius of the centreline should also be left on the pegs, just add it!</p> <p>Press REC (F3) to store the position of the staked point.</p> <p>Press PAGE (F6) to move to the Plot page.</p>	 <p>The screenshot shows a window titled "Stake-Stringline" with a close button (X). Below the title bar are tabs for "General", "Stake", "Infn", and "Plot". The "Stake" tab is active, displaying a table of data:</p> <table border="1"> <tbody> <tr> <td>Strg1 Task :</td> <td>Bike CL</td> </tr> <tr> <td>Chainage :</td> <td>0.037 m</td> </tr> <tr> <td>CL Offsct :</td> <td>0.161 m</td> </tr> <tr> <td>Strg1 Offset :</td> <td>0.161 m</td> </tr> <tr> <td>Strg1 Ht Diff:</td> <td>-0.032 m</td> </tr> <tr> <td>CL Ht Diff :</td> <td>-0.032 m</td> </tr> <tr> <td>CL Height :</td> <td>420.206 m</td> </tr> </tbody> </table> <p>At the bottom of the window, there is a navigation bar with buttons for "ALL", "DIST", "REC", "CH+", "<PAGE", and "PAGE>". A small "a" icon with an upward arrow is also visible.</p>	Strg1 Task :	Bike CL	Chainage :	0.037 m	CL Offsct :	0.161 m	Strg1 Offset :	0.161 m	Strg1 Ht Diff:	-0.032 m	CL Ht Diff :	-0.032 m	CL Height :	420.206 m
Strg1 Task :	Bike CL															
Chainage :	0.037 m															
CL Offsct :	0.161 m															
Strg1 Offset :	0.161 m															
Strg1 Ht Diff:	-0.032 m															
CL Ht Diff :	-0.032 m															
CL Height :	420.206 m															

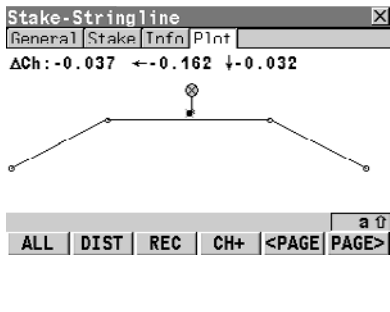
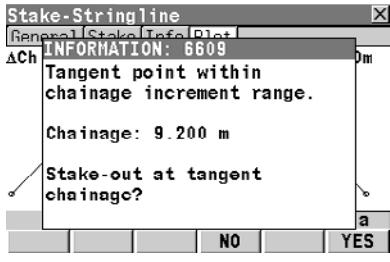
	Description	
4.	<p>The Plot page. This page gives you a graphic representation of the cross-section at the current chainage and your position relative to it. The plot page also shows you the numeric values of the difference to the position to stake-out.</p> <p>Press CH+ (F4) to increase the current chainage by the defined chainage increment.</p> <p>Stake out the point at chainage 5.000 following steps 6 to 7.</p>	
5.	<p>Press CH+ (F4) to increase the current chainage by the defined chainage increment. A message box comes up telling you that there is a tangent point, the start point of the curve, within the chainage increment range.</p> <p>Press YES (F6) to stake out the tangent points.</p>	
6.	<p>Stake out all points and tangent points along the centre line until the last chainage by repeating steps 6 to 8.</p>	

13.5

Exercise 3: Staking Out Slopes

Description

- In this exercise the slopes for the cut and fills of the bike path should be marked. The catch point (intersection between natural surface and design slope) should be staked out and marked.

Preparation

- To run this exercise you need an open space of about 30 x 30 m, 10 pegs and a tape.

Uploading the data

- This exercise uses the tutorial data distributed with the "SmartWorx DVD".
- Copy all data from GPS1200 or TPS1200\GPS1200 or TPS1200_SampleData\Applications\RoadRunner\Tutorial\Onboard\Exercise3\ to the CF card under \DBX\.
- If you continue from Exercise 1 you can use RR_Exercise_1 as well.

Selecting the project and the task

Description Option 1 - Continuing from Exercise 1	
1.	Access RoadRunner Setup . In Exercise 1, a task was created for the stringline. In Exercise 3, you will create a task for the slope.
2.	Select Application: RR Road , Select Stake/Check: Stake , Select Method: Slope , Select Mode: Advanced , Ensure Project: RR_Exercise_1 is selected. Press CONT (F1) to access Task Management .

RoadRunner Setup [X]

Application : RR Road

Stake/Check : Stake

Method : Slope

Mode : Advanced

Project : RR_Exercise_1

Fixpoint Job : Tutorial Points



Meas Job : Tutorial Meas

Road Job : Tutorial Road

DTH Job : <None>

Q2 a ↑

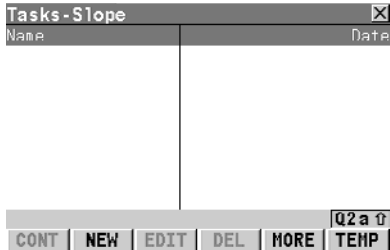
CONT CONF PROJ DATA

Description Option 1 - Continuing from Exercise 1		
3.	<p>Press NEW (F2) to start the Selection Wizard. The selection wizard guides you through the selection of the new task. The new task is created when you reach the last screen of the Selection Wizard and end it with FINSH (F1).</p>	
4.	<p>Select Task Name: Fill Left, Select Shift Horiztl: None, Select Shift Verticl: None. Press NEXT (F1) to continue.</p>	
5.	<p>Select Layer: Initial Cut/Fill, Select Select View: Cross-Section, Select Plot Chainage: 0.000. Press NEXT (F1) to continue.</p>	

Description Option 1 - Continuing from Exercise 1	
<p>6.</p>	<p>Select Left StrIn: Left Slope. Select Right StrIn: Left Hinge. Select this line by using the (F2) and (F3) keys. Press NEXT (F1) to continue.</p>
<p>7.</p>	<p>Select Hinge: Right StrIn, Select Use Min/Max: No. Press FINSH (F1) to confirm the changes, end the Selection Wizard and create the new task. The new task you have created is stored with all the defined settings as part of the project. To run the stake out it is only necessary to call up the task again.</p>
<p>Description Option 2 - Starting with Exercise 3</p>	
<p>1.</p>	<p>Press CONT (F1) to access RoadRunner Setup. (these steps continue from Exercise 1a)</p>

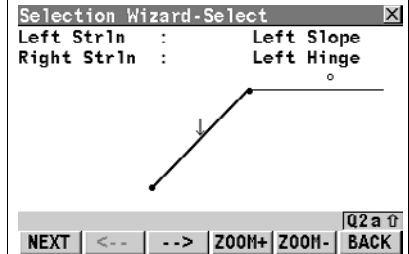

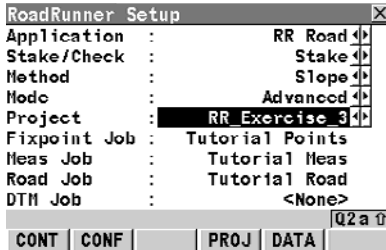
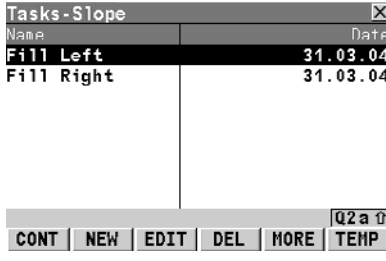
Description Option 2 - Starting with Exercise 3								
2.	<p>Select Application: RR Road,</p> <p>Select Stake/Check: Stake,</p> <p>Select Method: Slope,</p> <p>Select Mode: Advanced,</p> <p>Ensure Project: RR_Exercise_3 is selected.</p> <p>Press CONT (F1) to access Task Management.</p>	 <p>RoadRunner Setup</p> <p>Application : RR Road</p> <p>Stake/Check : Stake</p> <p>Method : Slope</p> <p>Mode : Advanced</p> <p>Project : RR_Exercise_3</p> <p>Fixpoint Job : Tutorial Points</p> <p>Heas Job : Tutorial Heas</p> <p>Road Job : Tutorial Road</p> <p>DTM Job : <None></p> <p>CONT CONF PROJ DATA Q2a</p>						
3.	<p>Highlight and select the existing task Fill Left.</p> <p>Press CONT (F1).</p>	 <p>Tasks - Slope</p> <table border="1"> <thead> <tr> <th>Name</th> <th>Date</th> </tr> </thead> <tbody> <tr> <td>Fill Left</td> <td>31.03.04</td> </tr> <tr> <td>Fill Right</td> <td>31.03.04</td> </tr> </tbody> </table> <p>CONT NEW EDIT DEL MORE TEMP Q2a</p>	Name	Date	Fill Left	31.03.04	Fill Right	31.03.04
Name	Date							
Fill Left	31.03.04							
Fill Right	31.03.04							

Staking the catch point

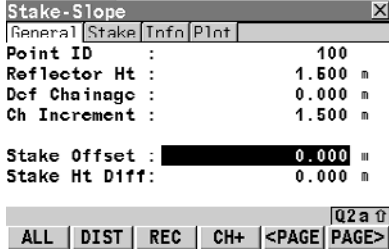
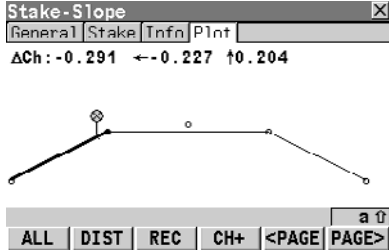
	Description	
1.	<p>The General page.</p> <p>Enter a point ID Point ID;</p> <p>Enter the reflector height Reflector Ht; for TPS</p> <p>Enter the antenna height Antenna Ht; for GPS</p> <p>Enter Def Chainage: 0.000,</p> <p>Enter Ch Increment: 5.000,</p> <p>Leave Stake Offset: and Stake Ht Diff: at 0.</p> <p>Press PAGE (F6) to move to the Plot page.</p>	
2.	<p>The Plot page.</p> <p>This page shows the measured position in relation to the cross section at the current chainage.</p> <p>Press DIST (F2) to populate the Plot page with the values for the current measured position.</p> <p>Bring the values ΔChainage: and ΔOffset: as close to zero as required.</p> <p>Mark the position of the catch point.</p> <p>Press PAGE (F6) to move to the Info page.</p>	

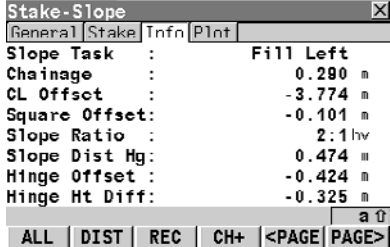
	Description																									
3.	<p>The Info page.</p> <p>This page shows all the information to be left on the peg for the guys who actually build your bike path.</p> <p>This page is user defineable. So, if you are used to seeing the displayed values in a different sequence or want to see other items simply select them in the Configuration.</p>	 <p>The screenshot shows a window titled "Stake-Slope" with a close button (X). It has four tabs: "General", "Stake", "Info", and "Plot". The "Stake" tab is active, displaying the following data:</p> <table border="1"> <tr> <td>Slope Task</td> <td>:</td> <td>Fill Left</td> </tr> <tr> <td>Chainage</td> <td>:</td> <td>0.290 m</td> </tr> <tr> <td>CL Offset</td> <td>:</td> <td>-3.774 m</td> </tr> <tr> <td>Square Offset</td> <td>:</td> <td>-0.101 m</td> </tr> <tr> <td>Slope Ratio</td> <td>:</td> <td>2:1_{hv}</td> </tr> <tr> <td>Slope Dist Hg</td> <td>:</td> <td>0.474 m</td> </tr> <tr> <td>Hinge Offset</td> <td>:</td> <td>-0.424 m</td> </tr> <tr> <td>Hinge Ht Diff</td> <td>:</td> <td>-0.325 m</td> </tr> </table> <p>At the bottom right of the window, there is a small icon of a hand with an arrow pointing up. Below the window, there is a control bar with buttons: ALL, DIST, REC, CH+, <PAGE, and PAGE>.</p>	Slope Task	:	Fill Left	Chainage	:	0.290 m	CL Offset	:	-3.774 m	Square Offset	:	-0.101 m	Slope Ratio	:	2:1 _{hv}	Slope Dist Hg	:	0.474 m	Hinge Offset	:	-0.424 m	Hinge Ht Diff	:	-0.325 m
Slope Task	:	Fill Left																								
Chainage	:	0.290 m																								
CL Offset	:	-3.774 m																								
Square Offset	:	-0.101 m																								
Slope Ratio	:	2:1 _{hv}																								
Slope Dist Hg	:	0.474 m																								
Hinge Offset	:	-0.424 m																								
Hinge Ht Diff	:	-0.325 m																								
4.	<p>Depending on the workflow you favour you can now either stake all catchpoints on one side of the centre line or flip between the right and left slope of the cut.</p> <ul style="list-style-type: none"> • To work ahead on one side of the road simply press CH+ (F4) to increase to the next chainag • To change to the right side of the cut simply press ESC to return to Task Management. Select Fill Right and move to the right side of the centre line. 																									
5.	<p>Continue with the stake out of the other catch points each 5 m by using CH+ (F4).</p>																									

	Description	
6.	As soon as you reach the area where the fill turns to a cut RoadRunner brings up a message box telling you that you are outside of the define slope and prompting if you want to continue with the last valid slope values. This is a useful feature if the design you get is not accurate enough and cuts/fills have to be extended.	

13.6

Exercise 4: Checking Road Layer Surface

Description

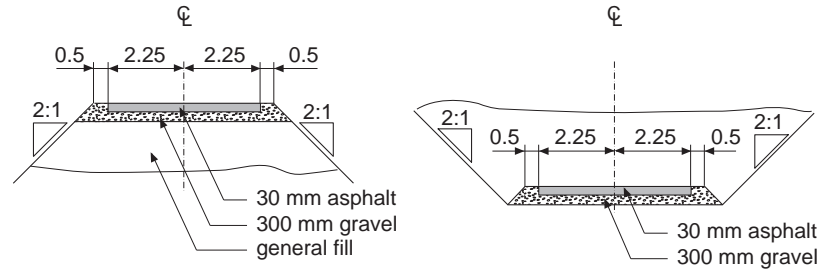

RR12_061

- A common task on construction sites is the as-built check of the work already completed. RoadRunner offers you for each stake out method an equivalent check method. The major difference between stake out and check is, that checks are based on random chain-ages. Therefore no **Stake** page exists for the check methods. In this exercise you will check the 300mm gravel layer of the of the street.
- When running checks with the layer method RoadRunner automatically detects the relevant part of the layer for the measured position. On the **Road Configuration, Stake** page you can choose if a warning should appear as soon as a point outside the defined limits is stored.

Preparation

- To run this exercise you need an open space of about 30 x 30 m, 10 pegs and a tape.

Uploading the data

- This exercise uses the tutorial data distributed with the "SmartWorx DVD".
- Copy all data from GPS1200 or TPS1200\GPS1200 or TPS1200_SampleData\Applications\RoadRunner\Tutorial\Onboard\Exercise4\ to the CF card under \DBX\.

- If you continue from Exercise 1 you can use RR_Exercise_1 as well.

Selecting the project and the task

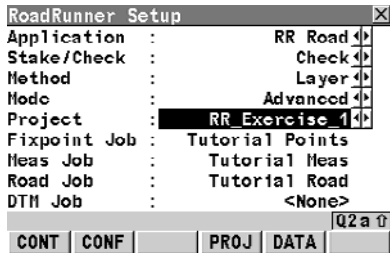
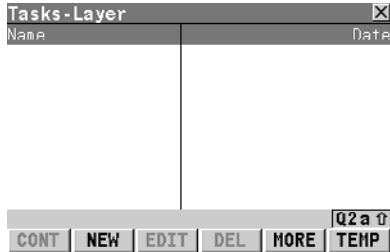
Description Option 1 - Continuing with Exercise 1						
1.	<p>Access RoadRunner Setup.</p> <p>In Exercise 1, a task was created for the stringline. In Exercise 3, a task was created for the slope. In Exercise 4, you will create a task for the layer.</p>					
2.	<p>Select Application: RR Road,</p> <p>Select Stake/Check: Check,</p> <p>Select Method: Layer,</p> <p>Select Mode: Advanced,</p> <p>Ensure Project: RR_Exercise_1 is selected.</p> <p>Press CONT (F1) to access Task Management.</p>	 <p>RoadRunner Setup</p> <p>Application : RR Road</p> <p>Stake/Check : Check</p> <p>Method : Layer</p> <p>Mode : Advanced</p> <p>Project : RR_Exercise_1</p> <p>Fixpoint Job : Tutorial Points</p> <p>Meas Job : Tutorial Meas</p> <p>Road Job : Tutorial Road</p> <p>DTH Job : <None></p> <p>CONT CONF PROJ DATA</p>				
3.	<p>Press NEW (F2) to start the Selection Wizard.</p> <p>The selection wizard guides you through the selection of the new task. The new task is created when you reach the last screen of the Selection Wizard and end it with FINSH (F1).</p>	 <p>Tasks-Layer</p> <table border="1"> <thead> <tr> <th>Name</th> <th>Date</th> </tr> </thead> <tbody> <tr> <td> </td> <td> </td> </tr> </tbody> </table> <p>CONT NEW EDIT DEL MORE TEMP</p>	Name	Date		
Name	Date					

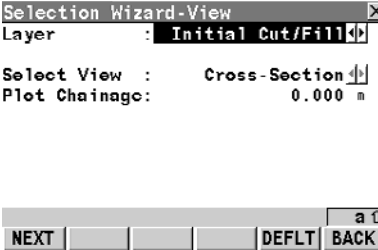
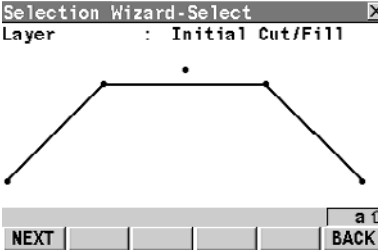
Description Option 1 - Continuing with Exercise 1		
4.	<p>Select Task Name: Init Cut/Fill, Select Shift Vertical: None. Press NEXT (F1) to continue.</p>	 <p>Selection Wizard-Start</p> <p>Task Type : Layer</p> <p>Task Name : Init Cut/Fill</p> <p>Shift Horizontal: None</p> <p>Shift Vertical: None</p> <p>NEXT</p>
5.	<p>Select Layer: Initial Cut/Fill, Select Select View: Cross-Section, Select Plot Chainage: 0.000. Press NEXT (F1) to continue.</p>	 <p>Selection Wizard-View</p> <p>Layer : Initial Cut/Fill</p> <p>Select View : Cross-Section</p> <p>Plot Chainage: 0.000 m</p> <p>NEXT DEFLT BACK</p>
6.	<p>The whole layer is shown. Press NEXT (F1) to continue.</p>	 <p>Selection Wizard-Select</p> <p>Layer : Initial Cut/Fill</p> <p>NEXT BACK</p>

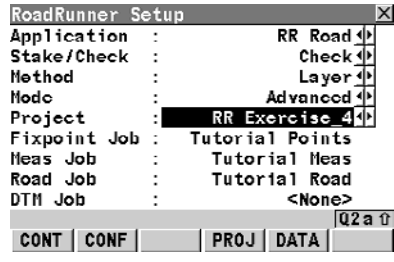
Description Option 1 - Continuing with Exercise 1	
<p>7. Select Exp endSlp: Yes, Select Use Min/Max: No, Press FINSH (F1) to confirm the changes, end the Selection Wizard and create the new task. The new task you have created is stored with all the defined settings as part of the project. To run the stake out it is only necessary to call up the task again.</p>	 <p>Selection Wizard-Define</p> <p>Centre line : TUTORIAL</p> <p>Exp endSlp : Yes</p> <p>Use Min/Max : No</p> <p>Min Chainage : 0.000</p> <p>Max Chainage : 32.399</p> <p>FINSH DEFLT BACK</p>
Description Option 2 - Starting with Exercise 4	
<p>1. Press CONT (F1) to access RoadRunner Setup. (these steps continue from Exercise 1a)</p>	
<p>2. Select Application: RR Road, Select Stake/Check: Check, Select Method: Layer, Select Mode: Advanced, Ensure Project: RR_Exercise_4 is selected. Press CONT (F1) to access Task Management.</p>	 <p>RoadRunner Setup</p> <p>Application : RR Road</p> <p>Stake/Check : Check</p> <p>Method : Layer</p> <p>Mode : Advanced</p> <p>Project : RR_Exercise_4</p> <p>Fixpoint Job : Tutorial Points</p> <p>Meas Job : Tutorial Meas</p> <p>Road Job : Tutorial Road</p> <p>DTM Job : <None></p> <p>CONT CONF PROJ DATA</p>

Description Option 2 - Starting with Exercise 4	
3.	<p>Highlight and select the task Layer Cut-Fill. Press CONT (F1).</p>

Tasks - Layer [X]

Name	Date
Layer Cut-Fill	30.03.04

Q2a ↑

CONT NEW EDIT DEL MORE TEMP

Checking the layer

Description	
1.	<p>The General page. Enter the point ID Point ID:, Enter the reflector height Reflector Ht:, for TPS Enter the antenna height Antenna Ht:, for GPS If the points to pick up are on a certain chainage, you would rather work with the stake out of layers which lets you define a chainage. Press PAGE (F6) to move to the Plot page.</p>

Check - Layer [X]

General	Info	Plot
Point ID :	100	
Reflector Ht :	1.500 m	
Check Ht Diff:	0.000 m	

Q2a ↑

ALL DIST REC <PAGE PAGE>

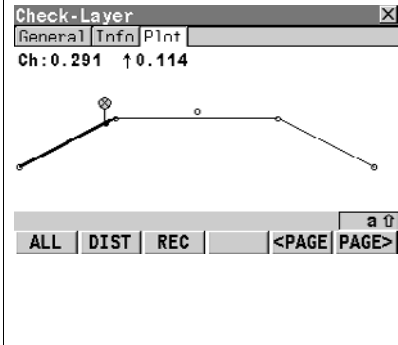
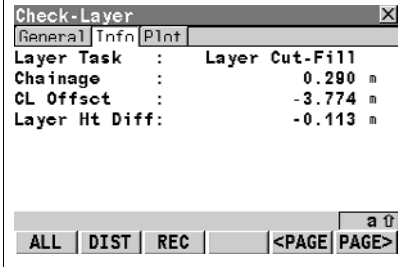
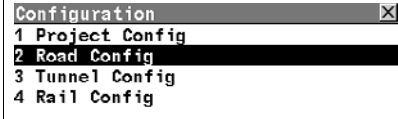
Description	
<p>2. The Plot page.</p> <p>This page shows the measured position in relation to the cross section at the current chainage.</p> <p>Press DIST (F2) to populate the Plot page with the values for the current measured position.</p> <p>Bring the values ΔChainage: and ΔOffset: as close to zero as required.</p> <p>Mark the position of the catch point.</p> <p>Press PAGE (F6) to move to the Info page.</p>	 <p>Check-Layer [X]</p> <p>General Infn Plot</p> <p>Ch: 0.291 ↑ 0.114</p> <p>Layer Task : Layer Cut-Fill Chainage : 0.290 m CL Offset : -3.774 m Layer Ht Diff: -0.113 m</p> <p>ALL DIST REC <PAGE PAGE></p>
<p>3. The Info page.</p> <p>In addition to the values displayed on the Info page you are interested in the grade of the centre line.</p> <p>As the Info page is user defineable you will simply add it to the already displayed item.</p> <p>Press SHIFT CONF (F2) to access Configuration.</p>	 <p>Check-Layer [X]</p> <p>General Infn Info</p> <p>Layer Task : Layer Cut-Fill Chainage : 0.290 m CL Offset : -3.774 m Layer Ht Diff: -0.113 m</p> <p>ALL DIST REC <PAGE PAGE></p>
<p>4. Choose Road Config.</p>	 <p>Configuration [X]</p> <p>1 Project Config 2 Road Config 3 Tunnel Config 4 Rail Config</p>

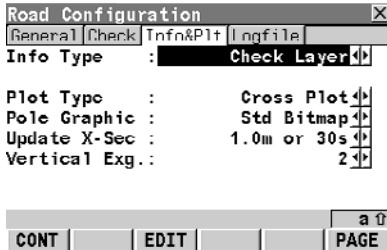
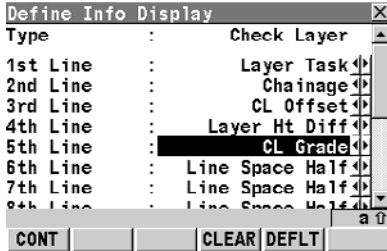
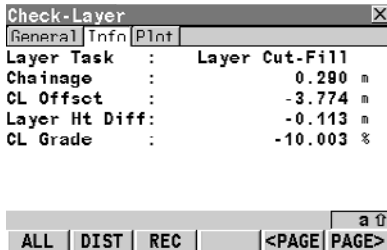
	Description	
5.	Press PAGE (F6) to move to the Info&Plt page. Select Info Type: Check Layer . Press EDIT (F3) to access Define Info Display .	
6.	Scroll down to the next empty line with either Line Space Half or Line Space Full and relace it with CL Grade . Press CONT (F1) twice to return to the Info page.	
7.	The field CL Grade: appears on the Info page	

13.7

Exercise 5: Shifting Design to Fit Existing Road Level

Description

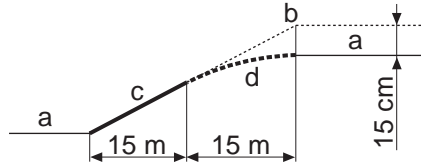

RR12_082



- a) Existing road level
- b) Original design
- c) Already built
- d) Shifted design, with 15cm shift at chainage 0 and 0 cm at chainage 15.

- While staking out the bike path you notice that the existing road level is 15 cm lower than it appears in the design you have received. The bike path is half finished, the construction team want to go on and do not want to remove the 15 m of gravel they have already placed. One way would be now to go back and change the complete vertical alignment of the bike path. RoadRunner offers you a much more efficient tool to deal with such every day construction task. After a short call the foreman agrees to your idea of simply shifting the remaining 17 meters of the path to match the existing road level.
- In the following exercise you will create a new X-slope task that includes this shift. At chainage 0.000 the shift applied should be -15cm to intersect with the existing road (a). To guarantee a smooth transition between the already finished part of the bike path (c) and the remaining part a linear shift will be used. This means the 15cm difference are distributed linearly along the remaining 17 m of the bike path.

Uploading the data

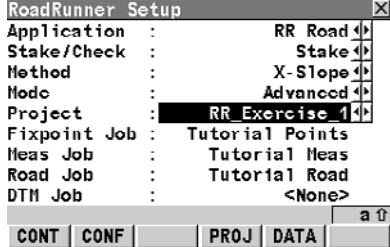

- This exercise uses the tutorial data distributed with the "SmartWorx DVD".
- Copy all data from GPS1200 or TPS1200\GPS1200 or TPS1200_SampleData\Applications\RoadRunner\Tutorial\Onboard\Exercise5\ to the CF card under \DBX\.
- If you continue from Exercise 1 you can use RR_Exercise_1 as well.

Selecting the project and the task

Description Option 1 - Continuing with Exercise 1		
1.	<p>Access RoadRunner Setup.</p> <p>In Exercise 1, a task was created for the stringline. In Exercise 3, a task was created for the slope. In Exercise 4, a task was created for the layer. In Exercise 5, you will create a task for the x-slope.</p>	
2.	<p>Select Application: RR Road,</p> <p>Select Stake/Check: Stake,</p> <p>Select Method: X-Slope,</p> <p>Select Mode: Advanced,</p> <p>Ensure Project: RR_Exercise_1 is selected.</p> <p>Press CONT (F1) to access Task Management.</p>	 <p>RoadRunner Setup</p> <p>Application : RR Road</p> <p>Stake/Check : Stake</p> <p>Method : X-Slope</p> <p>Mode : Advanced</p> <p>Project : RR_Exercise_1</p> <p>Fixpoint Job : Tutorial Points</p> <p>Meas Job : Tutorial Meas</p> <p>Road Job : Tutorial Road</p> <p>DTH Job : <None></p> <p>CONT CONF PROJ DATA</p>
3.	<p>Press NEW (F2) to start the Selection Wizard.</p> <p>The selection wizard guides you through the selection of the new task. The new task is created when you reach the last screen of the Selection Wizard and end it with FINSH (F1).</p>	 <p>Tasks-X-Slope</p> <p>Name Data</p> <p>CONT NEW EDIT DEL MORE TEMP</p>

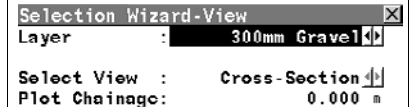
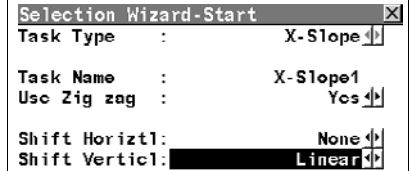
Description Option 1 - Continuing with Exercise 1	
4.	<p>Enter a task name Task Name:</p> <p>Select Use Zig zag: Yes. As you want to switch between the left and right side of the X-slope you are staking turn on the zig zag mode. RoadRunner will automatically detect to which side of the X-slope you are closer to. This gives you additional flexibility during the stake-out.</p> <p>Select Shift Horiztl: None. No horizontal shift should be applied to the X-slope.</p> <p>Select Shift Vertical: Linear. The 15cm difference should be distributed linear along 17 metres of the alignment, starting at chainage 0.000 with 15cm and ending at chainage 17.000 with 0 cm.</p> <p>Press NEXT (F1) to continue.</p>
5.	<p>Select Layer: 300mm Gravel.</p> <p>The default Plot Chainage: is by default the start chainage of the alignment.</p> <p>Press NEXT (F1) to continue.</p>

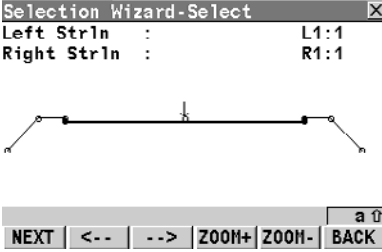

Description Option 1 - Continuing with Exercise 1		
6.	<p>Select Left StrIn: L1:1,</p> <p>Select Right StrIn: R1:1.</p> <p>Select this X-slope by using the (F2) and (F3) keys.</p> <p>Press NEXT (F1) to continue.</p>	
7.	<p>Select Reference Line: Left StrIn. All stake offsets and height differences applied would be relative to this stringline.</p> <p>Select Use Min/Max: No</p> <p>Press NEXT (F1) to continue.</p>	

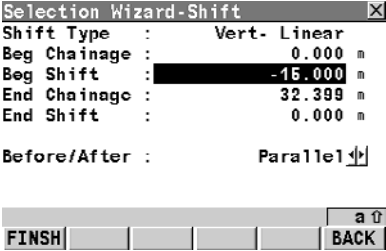
Description Option 1 - Continuing with Exercise 1	
<p>8. The vertical shift should start at chainage 0.000 with 15cm and should change back to the original design (shift = 0) at chainage 15.000.</p> <p>Select Before/After: Parallel.</p> <p>Press FINSH (F1) to confirm the changes, end the Selection Wizard and create the new task.</p> <p>The new task you have created is stored with all the defined settings as part of the project. To run the stake out it is only necessary to call up the task again.</p>	 <p>Selection Wizard-Shift</p> <p>Shift Type : Vert- Linear</p> <p>Beg Chainage : 0.000 m</p> <p>Beg Shift : -15.000 m</p> <p>End Chainage : 32.399 m</p> <p>End Shift : 0.000 m</p> <p>Before/After : Parallel</p> <p>FINSH BACK</p>
<p>9. The stake out for X-slopes works the same way as for slopes and stringlines. Move left and right of the centreline to see that the stringline you are staking out relative to changes depends on the side of the centreline you are. On the Plot page the position you are staking out relative to is always marked by a cross.</p>	

Index

A

Auto position	130, 186
2D + measure	188
Advanced	190

B

Batter rail	278
Beep near point	140

C

Carriage way	253
Catch point	254
Centreline	
Select	64
Chainage	254
Equation	281
Format	126
Gap	281
Overlap	281
Range	81
Configuration	
Project	126
Road	133
Cross section, update	143

Crown

Extras	244
Info page	172
Select	77
Stake out	119

D

Daylight point	254
Display mask	126
DTM	
Info page	183
Select	76

E

Extras

Crown	244
Layer	244
Slope	246
Stringline	234
X-slope	244

F

Finished road level	254
---------------------------	-----

G		L	
Guidance	135	Layer	204
H		Extras	244
Hinge point	253	Info page	178
Horizontal alignment	286	Select	74
I		Stake out	121
Indefinite triangle	100	Logfile	144
Indiv Stringline		M	
Stake out	99	Multiple chainage	282
Individual Stringline		N	
Info page	155	Natural surface	253
Info page	146	O	
Info screen	267	Original ground	253
J		P	
Job		Project	
DTM	193	Delete	200
Fixpoint	193	Edit	198
Measurement	193	New	197
Road	193	R	
		Reference point	276
		Road job	
		Delete	209
		New	207

S		Info page	166
Selection wizard	39	Manual	72, 247, 248
Centreline	64	Method	136
Define screen	49	Reference batter	59
DTM	76	Reference peg	58
Layer	74	Select	68
Road crown	77	Sign definition	128
Select screen	46	Stake out	273
Shift screen	61	Stake	
Slope	68	Height difference	86
Slope screen	57	Offset	86
Start screen	41	Stake mode	135
Stringline	64	Stake offset	265
View screen	44	Sign convention	265
X-slope	66	Working example	269
Shift	259, 287	Stake out	
Constant	43, 287	Chainage and offset	95
Linear	287	Crown	119
Parabolic	43, 287	Direct	265
Reverse	43, 287	Indirect	265
Sign convention	260	Indiv Stringline	99
X-slope	263	Layer	121
Shoulder	253	Stringline	97
Slope	256	X-slope	102
Batter rail	58	Station	254
Extras	246	Equation	281
Format	127		
Get current	247		

Stringline	203, 255
Extension	290
Extras	234
Info page	150
Select	64
Stake out	97
Surface	257
DTM	257
Layer	258

T

Task	206
Toe	254
Top	254
Traveller	279

V

Verge	253
Vertical alignment	286
Vertical exaggeration	143

W

Working corridor	136
------------------------	-----

X

X-slope	256
Extras	244
Format	127
Info page	161
Select	66
Stake out	102

Z

Zig zag	42, 79
---------------	--------

Total Quality Management: Our commitment to total customer satisfaction.



Leica Geosystems AG, Heerbrugg, Switzerland, has been certified as being equipped with a quality system which meets the International Standards of Quality Management and Quality Systems (ISO standard 9001) and Environmental Management Systems (ISO standard 14001).

Ask your local Leica Geosystems dealer for more information about our TQM program.

Leica Geosystems AG
Heinrich-Wild-Strasse
CH-9435 Heerbrugg
Switzerland
Phone +41 71 727 31 31
www.leica-geosystems.com

- when it has to be **right**

Leica
Geosystems